

JUKI OMAN

AUTHORIZED DISTRIBUTOR OF JUKI OMAN

ALVIN
INTERNATIONAL LLC



* Specifications and appearance are subject to change without prior notice for improvement.
* Read the instruction manual before putting the machine into service to ensure safety.
* This catalogue prints with environment-friendly soyink on recycle paper.
* Paper from responsible sources FSC™ C001712

MARCH, 2023 Printed in Japan(TN)



Registered Organization:
JUKI CORPORATION Head Office
The Scope of the Registration: The activities of research, development, design, sales, distribution, and maintenance services of industrial sewing machines, household sewing machines and industrial robots, etc., including sales and maintenance services of data entry systems.

Apparel

General Catalog 2023



JUKI Smart Solutions

Innovation with our Best Global Support

Let's start a SMART FACTORY with JUKI!

Sewing factories all over the world are seriously short of labor.

The key, in planning for future growth, is to steadily improve productivity even as the labor force dwindles. Simply put, the productivity per worker must get better than ever.

In JUKI's SMART FACTORY, advanced sewing machines, IoT technology, and years of experience in sewing factory efficiency come together to improve the productivity of every single worker.

Visualized



Connected



JUKI's proposal for a SMART FACTORY

The combination of various automated facilities and digitalized general-purpose sewing machines improve operation availability. Production time, which used to be manpower-dependent, is much reduced as a result. Production efficiency, meanwhile, is maximized by visualizing data on operation availability through networked production facilities.

NETWORKING

Visualize machine operation availability



JaNets
Juki advanced Network system

DIGITALIZATION

Much less downtime,
No more dependence
on worker skills



AUTOMATIZATION

Better productivity,
Better quality,
Lower labor costs



SHOP IMPROVEMENTS

Consulting service
based on data



DIGITALLY

Smart Solution

Inspire the Knowledge in Sewing Adjustment Epoch-making Sewing Systems in history

Digitalization of sewing machines redefines the traditional reliance of skilled and experienced veterans in the sewing factory.

Realization of digitalization and IoT technology also introduces new possibilities to the improvement of bottleneck quality, reproduction of optimum tension controls, and optimize time required for setup and maintenance processes.

Creation of exquisite seam

Digitalization of feeding locus^{*1}, needle thread tension etc. with JUKI developed innovative technology. With numerical representation of sewing variables, parameter adjustments are made simplified while improvising efficiency and quality.

Reproduction of sewing with IoT

While sewing adjustment data are stored within the machine, the information can be extracted by using an Android terminal^{*2} or USB device. Realizes requests such as [Wanting to reproduce seam quality from previous adjustments], [Wish to allow other machine to exact the same sewing quality as each other].

Visualization of production activities

Digitalization is not limited for adjustments of parameter data. JUKI Smart APP^{*3} allows users to view the output and operation ratio etc. of individual machines in graph format. Promoting analysis and problem solving based on the actual conditions.

LINE UP



Direct-drive, High-speed, Lockstitch Sewing System with automatic thread trimmer

DDL-9000C



Semi-Dry head, Digital Zigzag Stitching Sewing System

LZ-2290C



Semi-dry head, 2-needle Lockstitch Sewing System

LH-4500C



Computer-controlled, High-speed, Bartacking Sewing System

LK-1900BN

Computer-controlled, High-speed, Lockstitch, Button Sewing System

LK-1903BN



Computer-controlled, High-speed, Buttonholing Sewing System

LBH-1790AN



High-speed, Feed-off-the-arm, 3-needle Double Chainstitch Sewing System (Digital workstation)

MS-1261A/DWS



Computer-controlled, Eyelet Buttonholing Sewing System (Trimmer for Needle and Loper Thread with gimp)

MEB-3200C



Computer-controlled, Eyelet Buttonholing Sewing System <for jeans and cotton pants>

MEB-3900



Computer-controlled Cycle Machine with Input Function

AMS-221F





*1 DDL-9000C, LZ-2290C





*2 The sewing machine can be paired with equipment which supports NFC (Near Field Communication) only by holding the equipment over the sewing machine.





*3 Android OS Version 6.0 is recommended to use JUKI Smart APP. (Operation is confirmed with respect to Versions 5.0 and later.)



Contact JUKI distributor in your area for how to use the application software.





Pictographs for Function





Needle	
	2-needle
	Organized split needle bar
	3-needle
	4-needle





	Variable top-feed
	Belt-feed
	X-Y drive
	R-θ drive





	Shorter-thread remaining functions
	Button sewing
	Button sewing with neck wrapping
	Belt-loop attaching
	Pocket welting

Hook	
	Horizontal-axis hook (large)
	Horizontal-axis hook (3 fold-capacity)
	Vertical-axis hook (large)

Stitch system	
	Lockstitch
	Double chainstitch
	Single-thread chainstitch
	Pinpoint stitch

Function	
	Active tension
	Automatic thread trimmer
	Cloth puller
	Cloth cutting knife
	Stacker

Feed	
	Bottom-feed
	Needle-feed
	Bottom and variable top-feed
	Differential-feed

Stitch shape	
	Zigzag stitching
	Lockstitch buttonholing
	Eyelet buttonholing
	Bartacking

DI Dry-head, Intelligent Direct-drive Sewing Machine

DIGITALLY Smart Solution
Digitally Smart Solution

*sti/min is the abbreviation for "stitches per minute"

CONTENTS

Catalog of each model is also available.
For further details, please refer to each catalog.

1-needle, Lockstitch Machine

DDL-9000C DIGITALLY	01
DDL-9000C-FMS/PBN DIGITALLY	02
DDL-900C<EFLCS>	02
DDL-8000A	
DDL-7000A	
DDL-8700-7, 8700	03
DDL-5600N-7, 5600N	
DDL-5550N-7, 5550N	
DLU-5494N-7/IT-100A	04
DLU-5490N-7, 5490N	
DLN-9010A	
DLN-5410NDD-7	05
DLN-5410N-7, 5410N	
DLN-6390-7, 6390	
DLM-5400NDD-7, DMN-5420NDD-7	06
DLM-5400N-7, 5200N	
DMN-5420N-7	
DLD-5430N-7, 5430N	07

2-needle, Lockstitch Machine

LH-4578C-7, 4578C, 4588C-7 DIGITALLY	07
LH-3528A-7, 3528A, 3578A-7, 3578A	08
LH-3568A-7, 3568A, 3588A-7, 3588A	

Overlock / Safety Stitch Machine

MO-6700DA Series	09
MO-6800S/DD10, 22, 23 Series, MO-6800D/DD10, 22, 23 Series	
MO-6800D Series	10
MO-6800S Series	
MO-6900S Series	
MO-6900R Series	11
MO-6900J Series, 6900G Series	
MO-6900C Series	
MO-6914C-BD6-307/X81028	12
M-900/DJ Series	

Zigzag Stitching Machine

LZ-2290C-7, 2290C DIGITALLY	13
LZ-2280B	
LZ-2284B-7, 2284B	14
LZ-2287B	
LZ-2282N-7, 2282N	
LZ-2285N	15
LZ-2284NU-7, 2284NU, 2280NU	
LZ-2284C-7	
LZ-271, 391N	16

Post-bed Sewing Machine

DP-2100	16
LT-591	

Coverstitch Machine

MF-7500-U11(/UT), MF-7500D-U11(/UT)	17
MF-7500-C11, MF-7500D-C11	
MF-7500-E11, MF-7500D-E11	
MF-7912DRH24, MF-7913DRH24	18
MF-7900-U11(/UT), MF-7900D-U11(/UT)	
MF-7900-H11(/UT), MF-7900D-H11(/UT)	19
MF-7900-H22, 23(/UT), MF-7900D-H22, 23(/UT)	
MF-7900D-H24/UT, H25/UT	
MF-7900-E11(/UT), MF-7900D-E11(/UT)	20
MF-7900-E22(/UT), E23(/UT)	
MF-7200D-U10, K10	
MF-3620	21

Chainstitch Machine

MH-481-5, 481, 484-5, 484, 486-5	21
MH-380, 382	22
MS-3580	
MS-1261A/DWS DIGITALLY	
MS-1190, MS-1261	23
MP-200N	
ML-111U	

Button Sewing Machine

LK-1903BNB, 1903BN, 1903BN/BR35 DIGITALLY	24
LK-1903S	25
MB-1800A/BR10, 1800B, 1800S	
MB-1377, 1373	

Buttonholing Machine

LBH-1790ANB, 1790AN, 1795AN, 1796AN DIGITALLY	26
LBH-1790S	
LBH-780	27
MEB-3200C DIGITALLY	
MEB-3900	28

Bartacking Machine

LK-1900BNB, 1900BN, 1901BN, 1902BN DIGITALLY	29
LK-1900BNSS000/X75024 DIGITALLY	
LK-1900S, LK-1900SSS000/X75023	30

Shape-tacking Machine

LK-1910, 1920	30
---------------------	----

Computer-controlled Cycle Machine

AMS-221F-2516, 3020 DIGITALLY	31
AMS-210EN-1306, 1510, 2210, AMS-221EN-2516, 3020	32
AMS-210EN-1306/7450	33
AMS-210ENHL-2210/X90003	
AMS-221ENHS-3020	
AMS-221ENHS-3020/X90014, X90026	34
AMS-221ENHS-3020/X90005, X90006	
AMS-221ENTS-3020/X90002, 90004	
AMS-221ENHS-3020/7200	
AMS-221ENTS-3020/X90013	35
AMS-224EN-4530, 6030	
AW-3S	

Automatic Machine

APW-895NS, 895NL, 896NS	36
APW-895NE	37
AP-876, 874	
AB-1351	
MOL-254	38
AMB-289	
AC-172N-1790AN	
ASN-690	39
AE-200ANLA, AE-200ANLD	
PS-900-13090	40
PS-800-13085, 12080, 8045, 6045	
PS-800SB-8045CKZ/X88011	41
PS-800-2850	
PS-700	42

Software / System

PM-1	42
JaNets JT Simple	43
JUKI-ShuHaRi	45
JUKI e-learning	47

Option Parts

Plastic Bobbin	49
Ti-Mo-N Coating Loper	
Bird-Nest Prevention Device for DDL lockstich machine	50
DDL-9000C Series Optional Items	51
LK-1900 Shorter Thread remaining Kit	
LK-1900 Instant Button Sewing Clamp Kit	52



Direct-drive, High-speed, 1-needle, Lockstitch Sewing System with Automatic Thread Trimmer



DDL-9000C Premium Digital Digital

JUKI has digitalized the drive mechanism of the sewing machine which determines the "seam" quality, JUKI launches the new "direct-drive, high-speed, lockstitch sewing system with automatic thread trimmer" DDL-9000CF. This is the newest flagship lockstitch machine. Digitalized vertically- and horizontally-driven feed mechanism allows easy adjustment of settings such as the feed locus only on the operation panel according to the material to be sewn. Thanks to the digitalization, Optimum adjustment values required to produce high-quality seams can be stored, on a material-by-material basis, in memory and can be reproduced with ease. For sewing plants which produce diversified products using diversified materials, this feature is quite helpful to achieve stable seam quality.



DDL-9000C

Management, browsing and editing of data can be carried out on the application software

A "Two-way" contactless communication for parameter adjustment data can be conducted with the sewing machine by a commercial Android terminal. This feature allows sewing machines in a sewing line to be uniformly set and status checked quickly, thereby contributing to stabilization in product quality. Control panel is standardized with USB ports, promising simplicity in data management and system updates.



*Android OS Version 6.0 is recommended to use JUKI Smart APP. (Operation is confirmed with respect to Versions 5.0 and later.) Contact JUKI distributor in your area for how to use the application software.

The sewing machine can be paired with equipment which supports NFC (Near Field Communication) only by holding the equipment over the sewing machine.

Model name	DDL-9000C-FDS	DDL-9000C-FMS	DDL-9000C-FSH	DDL-9000C-SMS	DDL-9000C-SSH
Type	Premium Digital Type			Digital Type	
Application	Medium-weight		Heavy-weight	Medium-weight	Heavy-weight
Lubrication	Fully-dry head type	Semi-dry	Minute-quantity lubrication	Semi-dry	Minute-quantity lubrication
Max. sewing speed	4,000sti/min	5,000sti/min*1	4,500sti/min*2	5,000sti/min*1	4,500sti/min*2
Max. stitch length	5mm				
Needle*3	DBx1 · DPx5 (#11) #9~18 (Nm65~110)	DBx1 · DPx5 (#21) #20~23 (Nm125~160)	DBx1 · DPx5 (#11) #9~18 (Nm65~110)	DBx1 · DPx5 (#11) #20~23 (Nm125~160)	DBx1 · DPx5 (#21) #20~23 (Nm125~160)
Lift of the presser foot	By hand: 5.5mm, By knee: 15mm Auto: 1st stage 5.0 mm (*0.1~8.5mm), 2nd stage 8.5 mm (*8.5mm~13.5mm) *Adjustable on the operation panel				

*1 Stitch length of 4.00 mm or less: 5,000 sti/min; Stitch length of 4.05 - 5.00 mm: 4,000 sti/min
*2 Stitch length of 4.00 or less: 4,500sti/min; Stitch length of 4.05 - 5.00mm: 4,000sti/min
*3 Differs on a destination-by-destination basis

Semi-dry head, Direct-drive, High-speed, 1-needle, Lockstitch Sewing System with Automatic Thread Trimmer (Bird's nest prevention type)



DDL-9000C-FMS/PBN Premium Digital

DDL-9000C/PBN digitalizes the machine adjustment used to be handled based on personal hunches and experience. The machine comes with bird's nest prevention that commits to "seam quality". The newly-developed model totally eliminates bird's nests at the starting of sewing, which have been a conventionally inevitable factor when using machines with a thread trimmer. The length of thread remaining at the end of sewing is shortened.

- The machine eliminates the "bird's nest" at the starting of sewing.
- Only 3 mm long thread is left on the material at the end of sewing.



DDL-9000C-FMS/PBN

Model name	DDL-9000C-FMS/PBN
Type	Premium Digital Type
Application	Medium-weight
Lubrication	Semi-dry
Max. sewing speed	4,000sti/min
Max. stitch length	4mm
Needle	DBx1, DPx5 (Standard #11) #9~18 (Nm65~110)
Lift of the presser foot	Auto : 1st stage 5.0 mm (*0.1~8.5mm), 2nd stage 8.5 mm (*8.5mm~13.5mm) *Adjustable on the operation panel

Direct-drive, High-speed, 1-needle, Lockstitch Machine with Automatic Thread Trimmer (Electric Feed Length Control System<EFLCS>)



DDL-900C

JUKI's first high-speed lockstitch machine with Electric Feed Length Control System (EFLCS). The direct-drive motor, control box, and color LCD touch panel of this sewing machine are now combined with the Electric Feed Length Control System (EFLCS) – all integrated in the main body.



DDL-900CSMNBK

Model name	DDL-900CS-M	DDL900CS-H
Application	Medium weight	Heavy weight
Lubrication	Oil Shielding System	
Max. sewing speed	5,000sti/min	4,000sti/min
Max. stitch length	5mm	
Lift of the presser foot	Automatic: 9mm / Lever: 13mm	
Needle	DBx1 #14	DPx5 #21

Direct-drive, High-speed, 1-needle, Lockstitch Machine with Automatic Thread Trimmer



DDL-8000A

The DDL-8000A Series maintains JUKI's established seam quality and is provided with narrowed-down essential and simplified functions. It helps improve the work efficiency through operator assistance with its audio guidance.



Voice guidance for assisting the operator (newly-developed LCD panel)

This sewing machine is provided as standard with the voice guidance with clock function.



DDL-8000A

Model name	DDL-8000AS-MS	DDL-8000AS-SH	DDL-8000AS-SJ	DDL-8000AB-MS	DDL-8000AB-SH	DDL-8000AB-SJ
Specification	Standard type			Shorter-thread remaining type		
Application	Medium-weight	Heavy-weight	Jeans · Heavy-weight	Medium-weight	Heavy-weight	Jeans · Heavy-weight
Lubrication	Semi-dry	Minute-quantity lubrication		Semi-dry	Minute-quantity lubrication	
Max. sewing speed	5,000sti/min	4,500sti/min		5,000sti/min	4,500sti/min	
Max. stitch length	5mm		5mm (7mm)*	5mm		5mm (7mm)*
Lift of the presser foot	By hand: 5.5mm, Auto: 1st stage 8.5mm, 2nd stage 13mm, By knee: 15mm					
Needle	DBx1 (#11) #9~18 (134Nm65~110)	DBx1 (#21) #20~23 (134Nm125~160)	DPx5 (#21) #20~23 (134Nm125~160)	DBx1 (#11) #9~18 (134Nm65~110)	DBx1 (#21) #20~23 (134Nm125~160)	DPx5 (#21) #20~23 (134Nm125~160)

*When the optional long pitch kit is installed: 7mm (normal feed), 5mm (reverse feed)

Direct-drive, 1-needle, Lockstitch Machine with Automatic Thread Trimmer



DDL-7000A

The thread take-up lever which provides a wider sewing range is adopted. Needle bar stroke is 35 mm, with this feature, the sewing machine is able to sew many different types of materials ranging from light-weight ones to medium-weight denim.



DDL-7000A

Model name	DDL-7000AS-7	DDL-7000AH-7
Application	Light to medium weight	Heavy weight
Max. sewing speed	5,000sti/min	4,000sti/min
Max. stitch length	5mm	
Presser foot	By hand: 5.5mm, By knee: 13mm	
Needle	DB x 1 (#14) #14~#18	DP x 5 (#21) #20~#23

1-needle, Lockstitch Machine

1-needle, Lockstitch Machine

DDL-8700-7 DDL-8700

By thoroughly investigating and modifying the sewing mechanisms in order to achieve low-tension sewing, the machine flexibly responds to various kinds of materials and produces beautiful seams of consistent quality.

Model name	DDL-8700-7	DDL-8700
Application	Medium-weight	
Max. sewing speed	5,000sti/min	5,500sti/min
Max. stitch length	4mm	5mm
Presser foot	By knee: 13mm	
Needle	DBx1 (#14) #9~#18, 134 (Nm90)	

Model name	DDL-8700A-7, 8700A	DDL-8700H-7, 8700H
Application	Light-weight	Heavy-weight
Max. sewing speed	4,000sti/min	
Max. stitch length	4mm	5mm
Presser foot	By knee: 9mm	By knee: 13mm
Needle	DAx1 (#9) #9~#11, 134 (Nm65)	DBx1 (#21) #19~#23, 134 (Nm130)



DDL-8700-7

1-needle, Lockstitch Machine with Double-capacity Hook

DDL-5600N-7 DDL-5600N

The machine is capable of making well-tensed, beautifully finished seams, regardless of the type of heavy materials.

Model name	DDL-5600NJ-7, 5600NJ	DDL-5600NL-7, 5600NL
Application	Jeans	Heavy-weight
Max. sewing speed	4,000sti/min	3,000sti/min
Max. stitch length	5mm	8mm
Presser foot	By knee: 13mm	
Needle	DBx1 (#21) #20~#23, 134 (Nm130)	



DDL-5600N-7

1-needle, Lockstitch Machine

DDL-5550N-7 DDL-5550N

The thread take-up mechanism, feed mechanism, thread paths and hook have been further improved to enhance responsiveness to material changes and to ensure consistent stitch quality.

Model name	DDL-5550N-7	DDL-5550N
Application	Medium-weight	
Max. sewing speed	5,000sti/min	5,500sti/min
Max. stitch length	4mm	5mm
Presser foot	By knee: 13mm	
Needle	DBx1 (#14), 134 (Nm75)	DBx1 (#14), 134 (Nm90)

Model name	DDL-5550NA-7, 5550NA	DDL-5550NH-7, 5550NH
Application	Light-weight	Heavy-weight
Max. sewing speed	4,000sti/min	
Max. stitch length	4mm	5mm
Presser foot	By knee: 9mm	By knee: 13mm
Needle	DAx1 (#9), 134 (Nm65)	DBx1 (#21), 134 (Nm130)



DDL-5550N-7

1-needle, Lockstitch Machine

1-needle, Bottom and Variable Top-feed, Lockstitch Machine

DLU-5494N-7/IT-100A (with program shirring control device)

With its microcomputer control, the machine achieves high-quality shirring with consistency. The machine enables even inexperienced operators to perform shirring operation smoothly and easily.

Model name	DLU-5494N-7/IT-100A
Max. sewing speed	4,000sti/min
Max. stitch length	5mm (forward), 3mm (backward)
Max. top-feed amount	8mm (top feed amount varies depending on the type of gauge)
Presser foot	By knee: 13mm *When using auto-lifter AK85: 9mm
Needle	DBx1 (#14), 134 (Nm90)



DLU-5494N-7/IT-100A

1-needle, Bottom and Variable Top-feed, Lockstitch Machine

DLU-5490N-7 DLU-5490N

With its bottom and variable top-feed mechanism, the machine widely adapts to diversified applications and helps promote the production of upgraded-quality products while increasing efficiency.

Model name	DLU-5490N-7, 5490N
Max. sewing speed	4,500sti/min
Max. stitch length	5mm
Max. top-feed amount	8mm
Presser foot	By knee: 13mm
Needle	DBx1 (#14), 134 (Nm75)



DLU-5490N-7

Direct-drive, High-speed, Needle-feed, Lockstitch Machine

DLN-9010A

The needle feed mechanism, which is widely recognized as offering outstanding efficiency of feed and effectively preventing uneven material feed, responds to a wide range of applications such as the sewing of outerwear, runstitching of men's shirts, etc. and the attaching of various parts to garment bodies.

Model name	DLN-9010A-SS
Application	Light- to medium-weight
Max. sewing speed	5,000sti/min
Max. stitch length	4.5mm*
Presser foot	By knee: 15mm (max.), Auto: 10mm
Needle	DBx1 (#14) #9~#18, 134 (Nm90) Nm65~Nm110

*The max. sewing speed should be set at 4,000sti/min or less when the machine is used with a stitch length of more than 3.5mm.

Model name	DLN-9010A-SH
Application	Heavy-weight
Max. sewing speed	4,000sti/min
Max. stitch length	4.5mm
Presser foot	By knee: 15mm (max.), Auto: 10mm
Needle	DBx1 (#21) #20~#23, 134 (Nm130) Nm120~Nm160



DLN-9010A

1-needle, Lockstitch Machine

Direct-drive, 1-needle, Needle-feed, Lockstitch Machine with Automatic Thread Trimmer



DLN-5410NDD-7

Energy-saving servomotor is installed in the direct-drive style. The control panel which belongs equivalently to the highly-functional CP-180 family is built into the control box. With this panel, various sewing data ranging from the sewing speed to the production support functions can be adjusted.



DLN-5410NDD-7

Model name	DLN-5410NDD-7	DLN-5410NDDH-7	DLN-5410NDDJ-7
Application	Light to medium weight	Heavy weight	Jeans
Max. sewing speed	5,000sti/min	4,000 ti/min	
Max. stitch length	4mm	4.5mm	
Lift of the presser foot	By hand: 5.5mm, By knee: 13mm		
Needle	DB×1 (#14) #9~#18	DB×1 (#21) #20~#23	

1-needle, Needle-feed, Lockstitch Machine

DLN-5410N-7

DLN-5410N

The machine produces seams with accurate stitch length and prevents slippage of the upper fabric. The machine ensures beautiful seam quality free from stitch gathering, even when a hard-to-feed material is used.



DLN-5410N-7

Model name	DLN-5410N-7, 5410N	DLN-5410NH-7, 5410NH
Application	Light- to medium-weight	Medium- to heavy-weight
Max. sewing speed	5,000sti/min	4,000sti/min
Max. stitch length	4mm	4.5mm
Presser foot	By knee: 13mm	
Needle	DB×1 (#14), 134 (Nm90)	DB×1 (#21), 134 (Nm130)

Model name	DLN-5410NJ-7	DLN-5410NL
Application	Jeans	Heavy-weight (long stitch length type)
Max. sewing speed	4,000sti/min	3,000sti/min
Max. stitch length	4.5mm	6mm
Presser foot	By knee: 13mm	
Needle	DB×1 (#21), 134 (Nm130)	DB×1 (#21), 134 (Nm130)

High-speed, Cylinder-bed, 1-needle, Needle-feed Lockstitch Machine with Large Hook

DLN-6390-7

DLN-6390

The cylinder-bed lockstitch machine with a thread trimmer is designed for hemming the bottom of jeans, casual pants and work uniforms. The top-and bottom-roller style feed mechanism forms seams with increased consistency to achieve improved hemming quality while reducing uneven hems.



DLN-6390-7

Model name	DLN-6390-7	DLN-6390
Max. sewing speed	5,000sti/min	
Stitch length	Standard gears: 3.2mm (2.8mm) / Supplied gears: 2.3mm, 3.6mm / Optional gears: 2.1mm, 2.5mm, 4.2mm (utilized by changing pitch conversion gears)	
Presser foot	Max. 14mm	
Binder open / close type	Driven by air cylinder	Manual type
Cylinder-bed diameter	180mm	
Needle	UY180GVS Nm140 range of use: Nm90~Nm150 (equivalent to #14~#22.5)	

1-needle, Lockstitch Machine

Direct-drive, 1-needle, Lockstitch Machine with Vertical Edge Trimmer and Automatic Thread Trimmer



DLM-5400NDD-7 (Bottom-feed)

DMN-5420NDD-7 (Needle-feed)

With its highly operable knife mechanism, the machine helps promote the production of upgraded-quality products while increasing efficiency.

The control panel which belongs equivalently to the highly-functional CP-180 family is built into the control box. With this panel, various sewing data ranging from the sewing speed to the production support functions can be adjusted.



DLM-5400NDD-7

Model name	DLM-5400NDD-7	DMN-5420NDD-7
Max. sewing speed	4,500 sti/min	5,000 sti/min
Feed system	Bottom-feed	Needle-feed
Lift of the presser foot	By hand: 5.5mm, By knee: 13mm	
Needle	DB × 1 (#14) #9~#18	
Max. thickness of the material to be cut	4mm	

1-needle, Lockstitch Machine with Vertical Edge Trimmer

DLM-5400N-7 (Bottom-feed)

DLM-5200N

The knife is sharp enough to cut any type of material. The one-touch utility knife lever enhances the comfort of operation.



DLM-5400N-7

Model name	DLM-5400N-7
Max. sewing speed	4,500sti/min
Max. stitch length	4mm
Presser foot	By knee: 10mm
Needle	DB×1 (#14) #9~#18, 134 (Nm90)
Max. thickness of the material to be cut	4mm

Model name	DLM-5200N
Max. sewing speed	4,500sti/min
Max. stitch length	5mm
Presser foot	By knee: 10mm
Needle	DB×1 (#14), 134 (Nm90)
Max. thickness of the material to be cut	4mm

1-needle, Needle-feed, Lockstitch Machine with Vertical Edge Trimmer

DMN-5420N-7

The machine is a needle-feed type. The knife is sharp enough to cut any type of material.



DMN-5420N-7

Model name	DMN-5420N-7
Max. sewing speed	5,000sti/min
Max. stitch length	5mm
Presser foot	By knee: 10mm
Needle	DB×1 (#14) #9~#18, 134 (Nm90)
Max. thickness of the material to be cut	4mm

1-needle, Lockstitch Machine

1-needle, Differential-feed, Lockstitch Machine

DLD-5430N-7 DLD-5430N

With its highly reliable bottom-differential-feed mechanism, the machine promotes the production of upgraded-quality products while increasing efficiency.

Model name	DLD-5430N-7, 5430N
Max. sewing speed	4,500sti/min
Max. stitch length	5mm
Max. top-feed amount	Shirring 1:1.5 (max. 1:3*), Stretching 1:0.5
Needle bar stroke	30.7mm
Presser foot	By knee: 13mm
Needle	DBx1 (#14), 134 (Nm90)

*This ratio applies provided that the stitch length does not exceed 2.5mm.



DLD-5430N-7

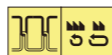

2-needle, Lockstitch Machine

Semi-dry head, 2-needle Lockstitch Sewing System

LH-4578C-7 LH-4578C LH-4588C-7

Seam quality is improved by introducing the separately-driven right and left active tension mechanisms.

A large hook of 1.8-fold capacity (as compared with the standard size hook) is adopted. As a result, frequency of thread changing is reduced in half. This is the world's first sewing machine not only for jeans and heavy-weight materials but also for foundation materials, medium-weight materials that is provided with a large hook. This sewing machine provides further stable seam quality.

The corner stitching capability is provided only on the LH-4588C-7. Changeover from the normal stitching to the corner stitching is carried out semi-automatically using the lever while ensuring ease of operation. This means that even the inexperienced operator can produce consistent seam quality while improving productivity.



LH-4588C-7



Management, browsing and editing of data can be carried out on the application software

A "Two-way" contactless communication for parameter adjustment data can be conducted with the sewing machine by a commercial Android terminal. This feature allows sewing machines in a sewing line to be uniformly set and status checked quickly, thereby contributing to stabilization in product quality. Control panel is standardized with USB ports, promising simplicity in data management and system updates.



*Android OS Version 6.0 is recommended to use JUKI Smart APP. (Operation is confirmed with respect to Versions 5.0 and later.) Contact JUKI distributor in your area for how to use the application software.

 The sewing machine can be paired with equipment which supports NFC (Near Field Communication) only by holding the equipment over the sewing machine.

Model name	LH-4578CFF	LH-4578CFS	LH-4578CFS-7	LH-4588CFS-7	LH-4578CFG-7	LH-4588CFG-7
Application	Foundation	Medium-weight		Jeans and heavy-weight materials		
Corner stitching (Organized split needle bar mechanism)	Not provided		provided	Not provided	provided	
Max. sewing speed	3,000sti/min					
Max. stitch length	4mm	5mm		7mm		
Lift of the presser foot (max.)	13mm					
Needle	DPx5 #10 (#9~#16)	DP x 5 #14 (#9~#16)		DP x 5 #21 (#16~#23)		

2-needle, Lockstitch Machine

Semi-dry head, 2-needle, Lockstitch Machine

LH-3528A-7 LH-3528A LH-3578A-7 (with large hooks) LH-3578A (with large hooks)

This is the cutting-edge model 2-needle sewing machine which comes with substantially enhanced mechanisms such as the direct-drive mechanism, semi-dry head, new thread tension control mechanism and improved oiling system. All models of the LH-3500A Series are provided with a semi-dry head to eliminate staining with oil from the frame (the needle bar part).

*A thread tension control mechanism has been developed for each type of sewing machine in order to achieve the best-suited thread tension for its purpose.

*Two selectable new-method oiling mechanisms.



LH-3528A-7



Model name	LH-3528A-7	LH-3528A	LH-3578A-7	LH-3578A
Application	A: Light-weight, F: Foundation, S: Medium-weight, G: Jeans and heavy-weight		G: Jeans and heavy-weight	
Max. sewing speed	3,000sti/min		3,000sti/min	
Max. stitch length	5mm (F type: 4mm)		5mm	
Needle gauge	3.2~34.9mm (1/8"~1-3/8")	2.4~38.1mm (3/32"~1-1/2")	3.2~25.4mm (1/8"~1")	3.2~38.1mm (1/8"~1-1/2")
Presser foot	By hand: 7mm, By knee: 13mm		By hand: 7mm, By knee: 13mm	
Needle	A: DPx5 (#9) #9~#16 F: DPx5 (#10) #9~#16	S: DPx5 (#14) #9~#16 G: DPx5 (#21) #16~#23	G: DPx5 (#21) #16~#23	

Semi-dry head, 2-needle, Lockstitch Machine with Organized Split Needle Bar

LH-3568A-7 LH-3568A LH-3588A-7 (with large hooks) LH-3588A (with large hooks)

The sewing machine with organized split needle bars is the only sewing machine in the industry that comes with the semi-dry head. It helps reduce poor-quality products due to oil stains even in the case of product items which have corner stitching sections.

*The semi-dry head sewing machine with organized split needle bars is only available from JUKI.

*A thread tension control mechanism has been developed for each type of sewing machine in order to achieve the best-suited thread tension for its purpose.

*Two selectable new-method oiling mechanisms.



LH-3568A-7



Model name	LH-3568A-7	LH-3568A	LH-3588A-7 (large hooks)	LH-3588A (large hooks)
Application	S: Medium-weight, G: Jeans and heavy-weight		G: Jeans and heavy-weight	
Max. sewing speed	3,000sti/min			
Max. stitch length	5mm			
Needle gauge	3.2~25.4mm (1/8"~1")		3.2~25.4mm (1/8"~1")	
Presser foot	By hand: 7mm, By knee: 13mm		By hand: 7mm, By knee: 13mm	
Needle	S: DPx5 (#14) #9~#16 G: DPx5 (#21) #16~#23		G: DPx5 (#21) #16~#23	

Direct-drive, Overlock / Safety Stitch Machine

MO-6700DA Series

JUKI's dry-head technology has been introduced to the MO-6700S, which has excellent seam quality and higher productivity. Only the parts which mainly contribute to oil splashes are improved to have dry mechanisms to create the semi-dry-head overlock machine, MO6700DA series. As a result, oil stains on the sewn products are eliminated.



MO-6714DA

Model name	MO-6704DA	MO-6714DA	MO-6716DA	MO-6743DA
Stitch type	1-needle overlock	2-needle overlock	Safety stitching	3-needle Safety stitching
Max. sewing speed	7,000sti/min			
Stitch length	0.8~4mm		1.5~4mm	
Needle gauge	—	2.0, 3.2mm	3.2, 4.8, 4.8+2.0, 3.2+2.0mm	3.2+2.0, 4.8+2.0mm
Overedging width	1.6, 3.2, 4.0, 4.8mm	2.0, 3.2, 4.0, 4.8mm	3.2, 4.0, 4.8, 6.4mm	3.2mm
Bottom differential feed ratio	For gathering 1:2 (Max. 1:4), For stretching 1:0.7 (Max. 1:0.6)			
Needle	DCx27 (excluding some subclass model)			

Direct-drive, High-speed, Overlock / Safety Stitch Machine

MO-6800S/DD10, DD22, DD23 Series

MO-6800D/DD10, DD22, DD23 Series (Semi-dry-head)

The sewing machine is a direct drive type in which a control box and an operation panel are integrated with the machine head. The machine achieves a practical maximum sewing speed of 7,000sti/min. The MO-6800D/DD series are eliminated oil stains on the sewing product with "dry" technology.



MO-6714DA

Model name	MO-6800S/DD10, 22, 23				MO-6800D/DD10, 22, 23			
	MO-6804S	MO-6814S	MO-6816S	MO-6843S	MO-6804D	MO-6814D	MO-6816D	MO-6843D
Stitch type	1-needle overlock	2-needle overlock	Safety stitching	3-needle safety stitching	1-needle overlock	2-needle overlock	Safety stitching	3-needle safety stitching
Max. sewing speed	7,000 sti/min							
Stitch length	0.6~3.8 (4.5) mm							
Needle gauge (mm)	—	2.0	3.0, 5.0	3.0+2.0, 5.0+2.0	—	2.0	3.0	5.0+2.0
Overedging width (mm)	1.5, 4.0	3.0, 4.0	4.0, 5.0, 6.0	3.0	4.0	2.0, 3.0, 4.0	4.0	3.0
Differential feed ratio	Gathering 1:2 (Max. 1:4), Stretching 1:0.7 (Max. 1:0.6)							
Needle	DCx27 (excluding some subclass model)							

Semi-dry-head, High-speed, Overlock / Safety Stitch Machine

MO-6800D Series

JUKI's dry technology has been adopted for the MO-6800S which produces seams of delicate quality and feel as well as achieves excellent cost-effectiveness. This is a semi-dry head overlock machine with the dry mechanism which eliminates oil-splashing problem. As a result, oil stains on the sewn products are eliminated.



MO-6816D

Model name	MO-6804D	MO-6814D	MO-6816D	MO-6843D
Stitch type	1-needle overlock	2-needle overlock	Safety stitching	3-needle safety stitching
Max. sewing speed	7,000sti/min			
Stitch length	0.6~3.8 (4.5) mm			
Needle gauge	—	2.0mm	3.0, 5.0mm	5.0+2.0mm
Overedging width	4.0mm	2.0, 3.0, 4.0mm	4.0, 5.0mm	3.0mm
Differential feed ratio	Gathering 1:2, Stretching 1:0.7			
Needle	DCx27 (excluding some subclass model)			

High-speed, Overlock / Safety Stitch Machine

MO-6800S Series

The MO-6800S Series responds to various kinds of sewing materials and processes, producing delicate and beautiful soft-to-the-touch seams while further reducing operating noise as well as increasing durability. This advanced overlock / safety stitch machine is easier to use and promises superior cost-effectiveness.



MO-6816S

Model name	MO-6804S	MO-6814S	MO-6816S
Stitch type	1-needle overlock	2-needle overlock	Safety stitching
Max. sewing speed	7,000sti/min		
Stitch length	0.6~3.8 (4.5) mm		
Needle gauge	—	2.0mm	3.0, 5.0mm
Overedging width	1.5, 4.0mm	3.0, 4.0mm	4.0, 5.0, 6.0mm
Differential feed ratio	For gathering 1:2 (Max. 1:4), For stretching 1:0.7 (Max. 1:0.6)		
Needle	DCx27 (excluding some subclass model)		

Super-high-speed, Overlock / Safety Stitch Machine

MO-6900S Series

Since the machine comes with a needle-thread take-up mechanism as well as a looper thread take-up mechanism, to offer upgraded responsiveness from light- to heavy-weight materials with a lower applied tension, it achieves well-tensed softfeeling seams that flexibly correspond to the elasticity of the material at the maximum sewing speed of 8,000 to 8,500sti/min. To offer improved sewing capabilities as well as to prevent stitching mishapes, the machine is equipped as standard with the needle thread heat remover and needle cooler.



MO-6914S

Model name	MO-6904S	MO-6914S	MO-6916S
Stitch type	1-needle overlock	2-needle overlock	Safety stitching
Max. sewing speed	8,500sti/min	8,000sti/min	
Stitch length	0.8~4mm		1.5~4mm
Needle gauge	—	2.0, 2.4, 3.2mm	2.0, 3.2, 4.0, 4.8, 4.8+2.0mm
Overedging width	1.6, 3.2, 4.0, 4.8mm	3.2, 4.0, 4.8mm	3.2, 4.0, 4.8, 6.4mm
Differential feed ratio	Gathering 1:2 (max. 1:4), Stretching 1:0.7 (max. 1:0.6)		
Needle	DCx27 (excluding some subclass model)		

Overlock / Safety Stitch Machine

High-speed, Variable Top-feed, Overlock / Safety Stitch Machine

MO-6900R Series

The locus of the top feed dog increases the surfaces of the top feed dog that horizontally synchronize with the bottom feed dog, to reliably feed the materials without damaging them. The feed mechanism smoothly feeds light-weight materials softly or feeds heavy-weight materials with an increased cloth-biting force. The fulcrum of the top feed locus can be set at the bestsuited position according to the material or process.

Model name	MO-6904R	MO-6914R	MO-6916R
Stitch type	1-needle overlock	2-needle overlock	Safety stitching
Max. sewing speed	7,000sti/min, 6,000sti/min		
Stitch length	0.8~4mm		1.5~4mm
Needle gauge	—	2.0mm	3.2, 4.8, 4.8+2.0mm
Overedging width	3.2, 4.0, 4.8, 6.4mm	3.2, 4.0mm	3.2, 4.0, 4.8, 6.4mm
Differential feed ratio	Gathering 1:2 (max. 1:4), Stretching 1:0.7 (max. 1:0.6)		
Needle	DCx27 (excluding some subclass model)		



MO-6914R

Overlock / Safety Stitch Machine for Extra Heavy-weight Materials

MO-6900J Series (variable top-feed)

MO-6900G Series (Differential-feed)

The machine incorporates a mechanism and parts that are optimum for the sewing of extra heavy-weight materials, such as an extra high-lift type upper looper, tractor foot and coarse type feed dog. It demonstrates an excellent performance ability in the sewing of various kinds of heavy-weight materials such as jeans, raised fabric materials, mats and carpets.



MO-6916J

Model name	MO-6904J	MO-6914J	MO-6916J	MO-6904G	MO-6914G	MO-6916G
Stitch type	1-needle overlock	2-needle overlock	Safety stitching	1-needle overlock	2-needle overlock	Safety stitching
Max. sewing speed	6,000sti/min					
Stitch length	2.5~5mm	2.5~4mm	2.5~5mm	2.5~5mm	2.5~4mm	2.5~5mm
Needle gauge	—	2.6mm	4.8mm	—	2.6mm	4.8mm
Overedging width	4.8mm	6.4mm	4.8, 6.4mm	4.8mm	6.4mm	4.8, 6.4mm
Differential feed ratio	Gathering 1:1.75 (max. 1:3.8) Stretching 1:0.7 (max. 1:0.6)	Gathering 1:2 (max. 1:3.8) Stretching 1:0.8 (max. 1:0.6)	Gathering 1:1.75 (max. 1:3.8) Stretching 1:0.7 (max. 1:0.6)	Gathering 1:1.75 (max. 1:3.8) Stretching 1:0.7 (max. 1:0.6)	Gathering 1:2 (max. 1:3.8) Stretching 1:0.8 (max. 1:0.6)	Gathering 1:1.75 (max. 1:3.8) Stretching 1:0.7 (max. 1:0.6)
Needle	DOx5 (excluding some subclass model)					

Super-high-speed, Cylinder-bed, Overlock Machine

MO-6900C Series

The machine provided with a small-in-diameter cylinder bed, is capable of runstitching or blind-hemming tubular materials, such as sleeve cuffs, with ease.

Model name	MO-6904C	MO-6914C
Stitch type	1-needle overlock	2-needle overlock
Max. sewing speed	8,000sti/min	
Stitch length	0.8~3.5mm	
Needle gauge	—	2.0mm
Overedging width	3.2, 4.0, 4.8mm	3.2, 4.0mm
Bottom differential feed ratio	Gathering 1:2.3 (max. 1:4.5), Stretching 1:0.8	
Needle	DCx27	



MO-6914C

Overlock / Safety Stitch Machine

High-speed, Cylinder-bed, 2-needle Overlock Machine

MO-6914C-BD6-307/X81028 (variable top-feed type)

The machine comes with the top feed dog that moves along an ideal locus. The feed dog securely catches the material and allows the multi-layer portion of a material to be fed under it with consistency. In addition it helps finish uniform seams while preventing the presser foot from jumping and smoothly feeds the material without fail. Compact-shape of the cylinder effectively prevents the material from being fed unevenly and from twisting in various kinds of sewing of tubular materials eg., joining sleeve cuffs of which diameter is small and blind hemming long materials.

Model name	MO-6914C-BD6-307/X81028
Stitch type	2-needle overlock
Max. sewing speed	7,000sti/min (longitudinal stroke of top feed dog is 6mm or less) 6,000sti/min (longitudinal stroke of top feed dog is 6~8.5mm)
Stitch length	0.8~3.5mm
Needle gauge	2.0mm
Overedging width	3.2mm
Bottom differential feed ratio	For gathering 1:2.3, For stretching 1:0.8
Needle	DCx27



MO-6914C-BD6-307/X81028

High-speed, Overlock / Safety Stitch Machine

M-900/DJ Series

The sewing machine is a direct drive type in which a control box and an operation panel are integrated with the machine head. The machine achieves a practical maximum sewing speed of 7,000sti/min. (excluding some subclass model).



The M900/DJ Series is has the side cutter with 2-point material sensor (DJ21, 22, 23) and the chain-off the thread trimming device with a 3-point material sensor (DJ33).



M-900/DJ20

model name	M952-16, 17	M952-13, 23, 52	M932-38, 44, 70, 86	M932-355, 551
Stitch type	1-needle overlock	2-needle overlock	Safety stitching	3-needle safety stitching
Max. sewing speed	7,000sti/min (excluding some subclass model)			6,000sti/min
Stitch length	3.7mm	2.7mm, 3.7mm	3.7mm, 5.3mm	3.7mm
Needle gauge	-	2.0mm, 2.5mm	3.0mm, 5.0mm	3.0+2.0mm, 5.0+2.0mm, 5.0+2.5mm
Overedging width	1.5mm, 4.0mm	4.0mm(3.0mm, 5.0mm), 4.5mm, 7.0mm	4.0mm, 5.0mm, 6.0mm	3.0mm, 3.5mm, 4.0mm
Differential feed ratio	0.7~1.7	0.7~1.7, 1.2~3.5	0.6~1.3, 0.7~1.7	0.7~1.7
Needle	DCx27			

Semi-Dry head, Digital Zigzag Stitching Sewing System

LZ-2290C-7  
LZ-2290C

The LZ-2290C series has two specifications of full digital and digital.

In the full digital specification, Vertical, Horizontal feeding mechanism are motorized to allow simplified parameter adjustments via the control panel. Feed timing which traditionally requires long duration of adjustment can now be simply changed via the control panel. System also allows changes from (Soft ↔ Standard ↔ Hard) settings based on the process suitability. Thanks to the adoption of the active presser foot, the presser foot pressure can be corrected according to the sewing speed, and jumping during high-speed sewing can be suppressed.



LZ-2290C-7

Management, browsing and editing of data can be carried out on the application software

A "Two-way" contactless communication for parameter adjustment data can be conducted with the sewing machine by a commercial Android terminal. This feature allows sewing machines in a sewing line to be uniformly set and status checked quickly, thereby contributing to stabilization in product quality. Control panel is standardized with USB ports, promising simplicity in data management and system updates.



*Android OS Version 6.0 is recommended to use JUKI Smart APP. (Operation is confirmed with respect to Versions 5.0 and later.) Contact JUKI distributor in your area for how to use the application software.

 The sewing machine can be paired with equipment which supports NFC (Near Field Communication) only by holding the equipment over the sewing machine.

Model name	LZ-2290CF-7	LZ-2290CS-7	LZ-2290CS
Type	Full Digital Type	Digital Type	
Max. sewing speed	5,000sti/min		
Max. zigzag width	8mm		
Max. stitch length	5mm		
Thread tension control mechanism	Rotary active tension	Rotary type (spring-adjustment type)	
Presser system	Active presser type (AK-156)	Spring type (AK155)	
Number of patterns for standard stitching	11 types / 20 patterns		
Custom pattern memory capacity	200 patterns		
Needle	DPx5 (#10), 438 (Nm75)		



High-speed, 1-needle, Lockstitch, Zigzag Stitching Machine (standard zigzag / standard wider zigzag)  

LZ-2280B



The standard zigzag stitching machine which creates softly finished seams. The needle rocking mechanism is provided with a triangular cam which helps produce beautiful seams with consistency.



LZ-2280BA

Model name	LZ-2280BA	LZ-2280BB
Stitch system	Standard zigzag	Standard wider zigzag
Stitch pattern		
Max. sewing speed	5,000sti/min	
Max. zigzag width	5mm	8mm
Max. stitch length	2.5mm	5mm
Needle	134 SUK (Nm70)	

High-speed, 1-needle, Lockstitch, Zigzag Stitching Machine (with standard / 3-step zigzag stitching pattern changeover function)  

LZ-2284B-7  
LZ-2284B

Designed to handle both standard and 3-step zigzag stitching, the machine offers increased availability. The direct-drive motor system has been adopted by all of the sewing machines with a thread trimmer. As a result, the sewing machine starts up swiftly and promises increased stop accuracy, thereby demonstrating improved responsiveness.



LZ-2284B-7

Model name	LZ-2284B-7, 2284B
Stitch system	Standard / 3-step zigzag
Stitch pattern	
Max. sewing speed	5,000sti/min
Max. zigzag width	5mm (standard) / 10mm (3-step)
Max. stitch length	2.5mm
Needle	134 SUK (Nm70)

High-speed, 1-needle, Lockstitch, Zigzag Stitching Machine (with 3-step zigzag / scallop stitching pattern changeover function)  

LZ-2287B



Designed to handle both 3-step zigzag and scallop stitching, the machine offers increased availability.



LZ-2287B

Model name	LZ-2287B
Stitch system	3-step zigzag / scallop
Stitch pattern	
Max. sewing speed	5,000sti/min
Max. zigzag width	10mm
Max. stitch length	2.5mm
Needle	134 SUK (Nm70)

High-speed, 1-needle, Lockstitch, Standard Zigzag Stitching Machine with Lower Knife  

LZ-2282N-7  
LZ-2282N

When used in the lace-attachment process for ladies' foundation, the machine sews lace on the garment body while simultaneously cutting only the garment body.



LZ-2282N-7

Model name	LZ-2282N-7, 2282N
Stitch system	Standard zigzag (with lower knife)
Stitch pattern	
Max. sewing speed	5,000sti/min
Max. zigzag width	4.5mm
Max. stitch length	2.5mm
Needle	438 (Nm70), DPx5 (#10)

Zigzag Stitching Machine

High-speed, 1-needle, Lockstitch, Zigzag Stitching Machine

LZ-2285N (fagoting)

The maximum needle throw is 10mm. The needle rocking mechanism means a higher degree of accuracy, thereby leading to a very high performance.



LZ-2285N

Model name	LZ-2285N
Stitch system	Fagoting
Stitch pattern	
Max. sewing speed	4,000sti/min
Max. zigzag width	8mm
Max. stitch length	2.2mm
Needle	438 (Nm80)

High-speed, 1-needle, Lockstitch, Zigzag Stitching Machine with Anti-material-slip Type

LZ-2284NU-7 (with standard / 3-step zigzag stitching pattern changeover function)

LZ-2284NU (with standard / 3-step zigzag stitching pattern changeover function)

LZ-2280NU

The sewing machine provided with an anti-material-slip function, which promises more beautifully finished seams, is included in three different model lineups. With its newly developed feed mechanism, the machine prevents "uneven feed of the upper and lower cloths" when sewing girdles and body suits made of slippery, elastic materials.



LZ-2280NU

Model name	LZ-2284NU-7, 2284NU	LZ-2280NU
Stitch system	Standard / 3-step zigzag	Standard zigzag
Stitch pattern		
Max. sewing speed	4,500sti/min	
Max. zigzag width	10.0mm (standard) 10.0mm (3-step)	10.0mm
Max. feeding amount	2.5mm (standard) 2.0mm (3-step)	
Needle	438 (Nm70), DPx5 (#10)	

High-speed, Cylinder-bed, 1-needle, Lockstitch, Zigzag Stitching Machine (with standard / 3-step zigzag stitching pattern changeover function)

LZ-2284C-7

The cylinder bed zigzag stitch machine is best suited to the circular stitching processes of tubular products such as girdles, shorts and swimwear.



LZ-2284C-7

Model name	LZ-2284C-7
Stitch system	Standard / 3-step zigzag
Stitch pattern	
Max. sewing speed	5,000sti/min Standard zigzag: zigzag width of 5mm or less 3-step zigzag: zigzag width set to 8mm or less
Max. zigzag width	Standard zigzag: 8mm, 3-step zigzag: 10mm
Max. stitch length	Standard zigzag: 2.5mm, 3-step zigzag: 2mm
Peripheral dimension of the cylinder section	322mm
Needle	438 (#75), DPx5 (#10)

Zigzag Stitching Machine

1-needle, Lockstitch, Zigzag Stitching Machine and Embroidering Sewing Machine

LZ-271 (for embroidering only)

LZ-391N

The machine is capable of embroidering names and marks on sewing products, as well as zigzag stitching, by simply changing the throat plate. When using this machine for zigzag stitching, the zigzag width and stitch length can be changed so that many different types of zigzag stitch can be sewn.



LZ-391N

Model name	LZ-271	LZ-391N
Max. sewing speed	2,000sti/min (with zigzag width is set to 10mm) 1,700sti/min (with zigzag width is set to 12mm)	
Needle bar stroke	33.4mm	
Zigzag width	0~12mm	
Stitch length	—	Max. 5mm
Needle	DBx1B (#11) #9~#18	DBx1B (#14) #9~#16

Post-bed Sewing Machine

Computer-controlled, Dry-head, Lockstitch Sleeve Setting Machine with Multi-programming Device



DP-2100

The machine is the culmination of JUKI's leading edge technologies to enable a sleeve setting process, which is the most difficult of all sewing processes, thereby more easily achieving upgraded seam quality. The machine comes with a newly developed belt feed mechanism that offers excellent responsiveness to materials and ease of their handling.



DP-2100

Model name	DP-2100
Max. sewing speed	3,500sti/min (feed pitch 1.5~4.0mm)
Stitch length (both top and bottom)	1.5~6mm
Amount of the alternating vertical movement of the presser foot and walking foot	Max. 3.5mm
Number of programs that can be input	99 programs
Number of steps that can be input (for one program)	30 steps
Needle	DPx17 #10~#14

1-needle, Lockstitch, Post-bed type Basting Machine

LT-591

This model is a specially developed machine to increase the sewing efficiency of basting process.



LT-591

Model name	LT-591
Max. sewing speed	600sti/min
Max. stitch length	Free
Needle	TVx7 (#14)

High-speed, Flat-bed, Top and Bottom Coverstitch Machine (universal type)

MF-7500-U11

MF-7500-U11/UT  

MF-7500D-U11 (semi-dry head)  

MF-7500D-U11/UT (semi-dry head)  

The machine can be used for the hemming process of the sleeves and bottoms of T-shirts and for the covering process for sportswear and knitwear. The front cover is trimmed to allow operators to bring their hands closer near the needle entry area, thereby increasing work efficiency in the covering process, etc.



MF-7523-U11

Model name	MF-7500/U11	MF-7500D/U11
Max. sewing speed	6,500sti/min	5,000sti/min
Needle gauge	3.2, 4.0, 4.8, 5.6, 6.4mm	5.6, 6.0, 6.4mm
Stitch length	1.2~3.6mm	
Needle	UY128GAS (#10S) #9S~#12S	

High-speed, Flat-bed, Top and Bottom Coverstitch Machine (collarett attaching)

MF-7500-C11

MF-7500D-C11 (semi-dry head) 

This model is best suited for attaching collarettes on underwear, briefs and knitwear. Ease of use is further improved by using the electromagnetic type tape cutter (TC16).

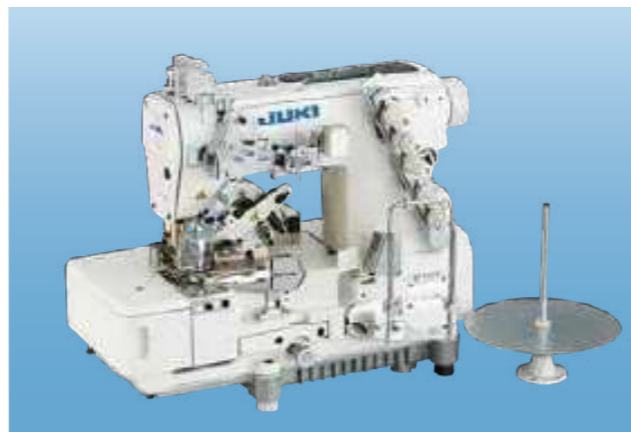

MF-7523D-C11

Model name	MF-7500-C11	MF-7500D-C11
Max. sewing speed	6,500sti/min	5,000sti/min
Needle gauge	3.2, 4.0, 4.8, 5.6, 6.4mm	4.0, 5.6, 6.4mm
Stitch length	1.2~3.6mm	
Needle	UY128GAS (#10S) #9S~#12S	

High-speed, Flat-bed, Top and Bottom Coverstitch Machine (elastic lace attaching with right hand fabric trimmer)

MF-7500-E11

MF-7500D-E11 (semi-dry head) 

The machine is intended for the elastic lace attaching of shorts, lingerie and foundations. The right hand fabric trimmer cuts the multi-layered section of joined seams without fail to achieve uniformly and beautifully finished seams, with the seams and material-edge aligned.

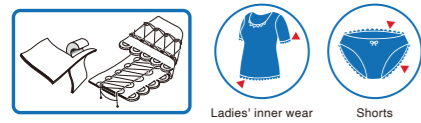

MF-7523-E11

Model name	MF-7500-E11	MF-7500D-E11
Max. sewing speed	6,500sti/min	5,000sti/min
Needle gauge	3.2, 4.0, 5.6, 6.4mm	4.0, 5.6, 6.4mm
Stitch length	0.9~3.6mm	
Needle	UY128GAS (#10S) #9S~#12S	

Semi-dry head, Cylinder-bed, Bottom Coverstitch Machine (with digital type top feed / For hemming (with left hand fabric trimmer))

MF-7912DRH24 

MF-7913DRH24 

This mechanism prevents problems, such as twist of fabric, uneven material feed, skew of grain and stitch gathering on multi-layered sections of material, which are likely to occur when sewing elastic materials, thereby achieving stable seam quality. Digital setting of the top feed mechanism enables easy adjustment of sewing even when the product to be sewn is changed, thereby reducing the setup time.

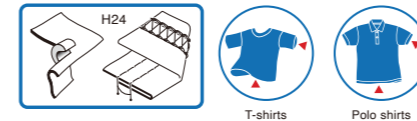

Model name	MF-7912DRH24	MF-7913DRH24
Stitch type	Semi-dry head, 2-needle bottom covering stitch	Semi-dry head, 3-needle bottom covering stitch
Max. sewing speed	5,000sti/min	
Feed mechanism	Digital type top feed	
Stitch length	0.9mm~3.6mm	
Needle	UY128GAS (#10S) #9S~#12S	

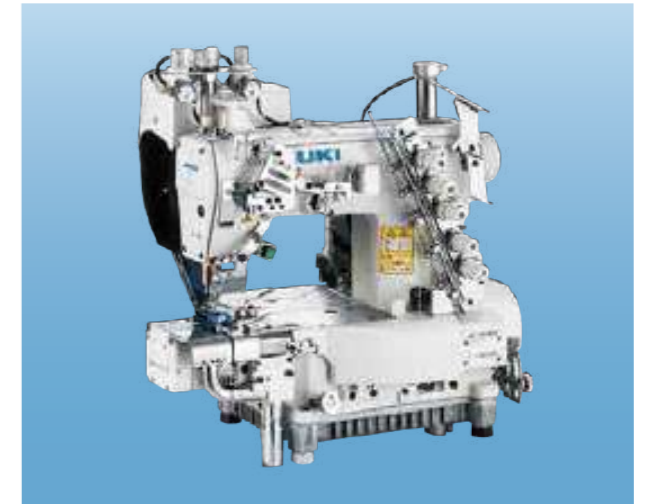

MF-7900DRH24

High-speed, Cylinder-bed, Top and Bottom Coverstitch Machine (universal type)

MF-7900-U11

MF-7900-U11/UT  

MF-7900D-U11 (semi-dry head) 

MF-7900D-U11/UT (semi-dry head)  

The machine can be used for the hemming process of the sleeves and bottoms of T-shirts and for the covering process for sportswear and knitwear. The front cover is trimmed to allow operators to bring their hands closer near the needle entry area, thereby increasing work efficiency in the covering process, etc.

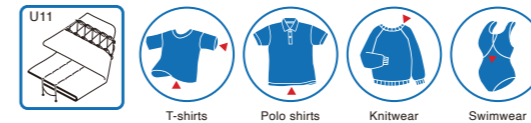

Model name	MF-7900-U11	MF-7900D-U11
Max. sewing speed	6,500sti/min	5,000sti/min
Needle gauge	3.2, 4.0, 4.8, 5.6, 6.4mm	4.0, 5.6, 6.4mm
Stitch length	0.9~3.6mm	
Needle	UY128GAS (#10S) #9S~#12S	



MF-7923-U11

High-speed, Cylinder-bed, Top and Bottom Coverstitch Machine (hemming)

MF-7900-H11

MF-7900-H11/UT  

MF-7900D-H11/UT  

The machine is intended for the hemming of knit shirts and T-shirts. This model is best suited to elastic-band wetting for swimwear, briefs, etc. It wets the elastic band which has been overlapped on the garment body.



Model name	MF-7900-H11	MF-7900D-H11
Max. sewing speed	5,000sti/min	
Needle gauge	5.6, 6.4mm	
Stitch length	0.9~3.6mm	
Needle	UY128GAS (#10S) #9S~#12S	



MF-7923-H11

Coverstitch Machine

High-speed, Cylinder-bed, Top and Bottom Coverstitch Machine
(hemming with left hand fabric trimmer)



MF-7900-H22, 23

MF-7900-H22, 23/UT

MF-7900D-H22, 23 (semi-dry head)

MF-7900D-H22, 23/UT (semi-dry head)

This model is best suited to hemming processes for sleeves and the bottoms of T-shirts, Polo shirts, etc. It comes with a left hand fabric trimmer for trimming fabric in parallel, at all times, to the seam with consistency. The upper knife stroke can be adjusted with ease.

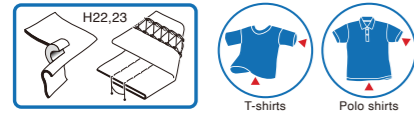

MF-7923D-H23

Model name	MF-7900-H22, 23/UT	MF-7900D-H22, 23
Max. sewing speed	6,000sti/min	5,000sti/min
Needle gauge	4.0, 4.8, 5.6, 6.4mm	4.8, 5.6, 6.4mm
Stitch length	0.9~3.6mm	
Needle	UY128GAS (#10S) #9S~#12S	

Semi-dry head, Cylinder-bed, Top & Bottom Coverstitch Machine
(hemming with left hand fabric trimmer, for extra light-weight materials)

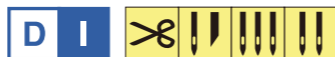

MF-7900D-H24/UT

MF-7900D-H25/UT (with sliding presser foot)

The machine is best-suited for the hemming of stretchy new material such as T-shirts, underwear and sportswear, etc. The machine produces seams with no semi-cylindrical swells by performing sewing while making the feeding lengths of the right and left needle threads equal. The sliding presser foot prevents the material hem from twisting during sewing and further eliminates oblique-feeding of the material in terms of its texture.

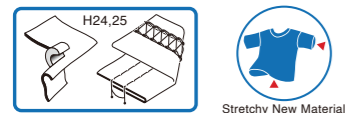

MF-7923D-H24

Model name	MF-7900D-H24	MF-7900D-H25
Max. sewing speed	5,000sti/min	
Needle gauge	3.2, 4.0, 5.6, 6.4mm	
Stitch length	0.9~3.6mm	
Needle	UY128GAS (#10S) #9~#12S	

Coverstitch Machine

High-speed, Cylinder-bed, Top and Bottom Coverstitch Machine
(elastic band attaching with right hand fabric trimmer)



MF-7900-E11

MF-7900-E11/UT

MF-7900D-E11 (semi-dry head)

MF-7900D-E11/UT (semi-dry head)

This model is best suited to endless flat elastic band sewing processes for briefs, boxer briefs, etc. The right hand fabric trimmer trims the fabric, even at a multi-layered joined part, to produce a beautiful finish with the seam and fabric edge aligned with consistency. The right hand fabric trimmer mechanism is a unit-structure to permit easy installation / removal. This contributes to easier adjustments, such as looper aligning.



Model name	MF-7900-E11/PL	MF-7900D-E11
Lubrication	Automatic (frame: no lubrication)	
Max. sewing speed	5,000sti/min	
Needle gauge	4.0, 5.6, 6.4mm	5.6mm
Stitch length	0.9~3.6mm	
Needle	UY128GAS (#10S) #9S~#12S	



MF-7913D-E11

High-speed, Cylinder-bed, Top and Bottom Coverstitch Machine (endless spandex elastic band attaching)



MF-7900-E22 (with manual binder)

MF-7900-E22/UT (with manual binder)

MF-7900-E23 (with air binder)

MF-7900-E23/UT (with air binder)

The machine is used for spandex elastic band sewing processes for briefs. The machine produces soft seams, making it best-suited for band attaching processes where seams are required to have sufficient elasticity.

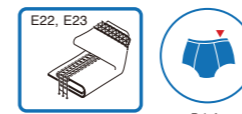

Model name	MF-7900-E22,23/PL
Lubrication	Automatic (frame: no lubrication)
Max. sewing speed	5,000sti/min
Needle gauge	5.6, 6.4mm
Stitch length	0.9~3.6mm
Needle	UY128GAS (#10S) #9S~#12S



MF-7923-E22

Semi-dry-head, Small-cylinder-bed, Top and Bottom Coverstitch Machine



MF-7200D-U10 (universal type)

MF-7200D-K10 (covering)

The small cylinder-bed and semi-dry head features have been achieved while placing priority on ease of use. Outer circumference of the cylinder section is 176mm!! The cylinder has the industry's smallest diameter. The outer circumference of the cylinder section has been reduced to 176mm. This allows the sewing machine to easily sew conventionally hard-to-sew small-in-diameter tubular parts such as the sleeve cuffs of sportswear and ladies' cut-and-sewn wear and the necklines of children's wear.

Model name	MF-7200D
Lubrication	Automatic (frame: no lubrication)
Max. sewing speed	4,000sti/min
Needle gauge	5.6, 6.4mm
Stitch length	Max. 4.2mm
Needle	UY128GAS (#10S) #9S~#12S



MF-7223D-U10

Coverstitch Machine

4-needle, Feed-off-the-arm, Flatseamers, Top and Bottom Coverstitch Machine

MF-3620

A new model with a direct-drive servomotor has been introduced as an addition to the MF Series of JUKI sewing machines. The new machine consumes only about half the power of the conventional models. The enhanced responsiveness (compared with the model equipped with the clutch motor) of the MF-3620 gives the operator complete control over the material when sewing curved sections. Safely within its new shield, the frame is equipped with mechanisms for micro-quantity lubrication and forced oil circulation. The thread take-up mechanism arranged on the outside of the arm prevents the entry of oil splashes and dust. The MF-3620 is also configured with JUKI's unique oil-thruster mechanism to protect the looper section from oil infiltration. Excess oil is speedily reclaimed via the new oil groove. A mounting base for the direct-drive type machine head is provided as standard with a hand pulley.

Model name	MF-3620-B (direct-drive type)	MF-3620 (belt-drive type)
Application	Light- to heavy weight (knit)	
Max. sewing speed	4,200sti/min	
Stitch length	1.6~2.5mm (standard 2.1mm)	
Needle gauge	5.2, 6.0mm	
Needle	FLx118GCS (#10S) #9S~#12S	
Retainer needle	FLG-8 (#8) #8~#11	
Installation method	Standard type (with hand pulley)	MT05 Wooder auxiliary plate



MF-3620



Chainstitch Machine

1-needle, Double Chainstitch Machine

MH-481-5

MH-481

MH-484-5 (differential-feed)

MH-484 (differential-feed)

MH-486-5 (bottom and variable top-feed)

The machine comes with a thread spreading mechanism and an adjustable needle guard to prevent stitch skipping. The thread clamp mechanism, tension release mechanism and needle thread draw-out mechanism enable the machine to leave thread of a uniform length after thread trimming, and prevent slip-off of the needle thread. All of these mechanisms contribute to upgraded sewing.

Model name	MH-481-5, 481	MH-484-5, 484	MH-486-5
Max. sewing speed	5,500sti/min		4,500sti/min
Stitch length	1~4mm	Main feed: 1~4mm Differential feed: 1~5.6mm	1~5mm
Presser foot	By knee: 10mm		By knee: 7mm
Needle	TVx7 (#11) #9~#18		TVx7 (#11) #9~#21



MH-481-5



Chainstitch Machine

High-speed, Flat-bed, 2-needle Double Chainstitch Machine

MH-380 (parallel 2-needle)

MH-382 (tandem 2-needle)

Accurate stitching performance and durable finished seams are particularly necessary in the chainstitching process. JUKI ensures high-quality sewing with a higher degree of consistency with its unique looper mechanism and consistent condensation stitching mechanism.

Model name	MH-380, 382
Max. sewing speed	6,000sti/min
Stitch length	1~4mm
Presser foot	By knee: 10mm
Needle	TVx7 (#14) #9~#21



MH-382, MH-380



Feed-off-the-arm, 3-needle Double Chainstitch Machine

MS-3580

This machine demonstrates increased feed efficiency to handle extra heavy weight 16-ply denim. Engineered with extra feeding strength for seaming the inside of jeans. The machine is best suited for lap seaming jeans, denim jackets, work uniforms, etc. constructed of heavy weight materials.

Model name	MS-3580S*1SN	MS-3580S*0SN
Application	Medium- to heavy-weight: jeans, denim jackets, work uniforms, etc.	
Max. sewing speed	4,500sti/min	
Stitch length	2.1~3.6mm (standard 3.2mm)	
Needle	UY130GS (standard) / Nm140 (#22)	
Top feed roller width	11.9mm	
Feed adjusting method	Main feed: Slide-type stitch -length adjusting method	
	Differential feed: Lever adjusting method	Without the differential feed capability
Installation method	To be installed on the table by means of an auxiliary drive assembly MT03	



MS-3580S



High-speed, Feed-off-the-arm, 3-needle Double Chainstitch Sewing System (Digital workstation)

MS-1261A/DWS (for heavy-weight)

Thanks to the thread guide located between the needle bar thread take-up and the intermediate tension release lever, the timing to tense the needle thread can be decreased. As a result, the machine is capable of beautiful stitches with a soft appearance even when heavy-weight material is used.

Management, browsing and editing of data can be carried out on the application software

A "Two-way" contactless communication for parameter adjustment data can be conducted with the sewing machine by a commercial Android terminal.

This feature allows sewing machines in a sewing line to be uniformly set and status checked quickly, thereby contributing to stabilization in product quality. Control panel is standardized with USB ports, promising simplicity in data management and system updates.



Model name	MS-1261AM	MS-1261A
Application	Medium- to heavy-weight	Extra heavy-weight
Max. sewing speed	5,500sti/min	
Needle gauge	5.6mm (7/32") 6.4mm (1/4") 7.1mm (9/32") 7.9mm (5/16") 9.5mm (3/8")	
Stitch length	1.4~4.2mm	
Needle	UY128GAS-NY (#19) #16~#22	UY128GAS-NY (#21) #16~#22
	UY128GAS (Nm120) Nm100~Nm140	UY128GAS (Nm130) Nm100~Nm140
Lubrication	Automatic Lubrication	



MS-1261A/DWS



*Android OS Version 6.0 is recommended to use JUKI Smart APP. (Operation is confirmed with respect to Versions 5.0 and later.) Contact JUKI distributor in your area for how to use the application software.

The sewing machine can be paired with equipment which supports NFC (Near Field Communication) only by holding the equipment over the sewing machine.

Chainstitch Machine

Feed-off-the-arm, Double Chainstitch Machine

MS-1190 (2-needle, for light- to medium weight) 

MS-1261 (3-needle, for heavy-weight) 

Thanks to the thread guide located between the needle bar thread take-up and the intermediate tension release lever, the timing to tense the needle thread can be decreased.

As a result, the machine is capable of beautiful stitches with a soft appearance even when heavy-weight material is used.

Model name	MS-1190	MS-1190M
Application	Light-weight	Medium-weight
Max. sewing speed	4,000sti/min	
Needle gauge	3.2mm (1/8")~6.4mm (1/4")	
Stitch length	1.2~3.2mm	
Needle	TVx64-NY (#12) #8~#14 B-64 (Nm80) Nm60~Nm90	TVx64-NY (#16) #12~#19 B-64 (Nm100) Nm80~Nm120

Model name	MS-1261M	MS-1261
Application	Medium- to heavy-weight	Extra heavy-weight
Max. sewing speed	3,600sti/min	
Needle gauge	5.6mm (7/32")~9.6mm (3/8")	
Stitch length	1.4~4.2mm	
Needle	UY128GAS-NY (#19) #16~#22 UY128GAS (Nm120) Nm100~Nm140	UY128GAS-NY (#21) #16~#22 UY128GAS (Nm130) Nm100~Nm140



MS-1261/V045

Pinpoint Saddle Stitching Machine

MP-200N

The machine is able to perform sewing with a reduced tension applied to the thread, thereby widening its application range. With its upgraded responsiveness to changes in materials and processes, the machine always produces beautiful and soft pinpoint stitches.



MP-200NL

Model name	MP-200NL	
Max. sewing speed	1,500sti/min (stitch length 6~8mm)	
Needle	Needle	ORGAN CPx1J (#22U) #18U~#22U
	Hook-needle	ORGAN CPx12J (#23) #19~#23
	Recommended yarn count	#30~#8, B46~B92, Nm=60/3~30/3

Model name	MP-200NS	
Max. sewing speed	2,000sti/min (stitch length 6mm or less)	
Needle	Needle	SCHMETZ 29C150 (Nm90) Nm80~Nm140
	Hook-needle	SCHMETZ 29C151 (Nm100) Nm80~Nm140
	Recommended yarn count	#60~#30, B33~B46, Nm=120/3~60/3

Single-thread, Chainstitch Basting Machine

ML-111U

Chainstitch is continuously formed with a single thread and by a blind looper which eliminates the need for a bobbin thread refilling. In addition, the basted seam can be easily undone.



ML-111U

Model name	ML-111U
Max. sewing speed	1,800sti/min
Max. stitch length	10mm
Presser foot	By knee: 12mm
Needle	TVx7 (#14) #11~#14

Button Sewing Machine

Computer-controlled, High-speed, Lockstitch, Button Sewing System



LK-1903BNB

(bird's nest preventing / shorter-thread remaining functions) 

Users who are conscious about the finished quality of products manually nip, with scissors, the thread remaining on the material after thread trimming at the end of sewing. Now, the button sewing machine with the bird's nest preventing/shorter thread remaining functions saves such users the trouble of nipping the thread, thereby preventing the sewing product from being damaged by manual thread-nipping with SCISSORS. *Use #60-80 (TEX22-30) polyester spun thread

LK-1903BN (standard type)

The machine achieves sewing speed of 2,700sti/min. The machine's starting, stopping, thread-trimming and automatic presser lifting speeds have been increased to significantly shorten total cycle time. With our original horizontal forced feed mechanism, the button carrier sets a button in position so that the operation is simplified. Furthermore, operator fatigue is reduced since what operator needs to do is only setting material and pressing a pedal.

LK-1903BN/BR35 (with button feeder)

With our original horizontal forced feed mechanism, the button carrier sets a button in position so that the operation is simplified. Furthermore, operator fatigue is reduced since what operator needs to do is only setting material and pressing a pedal.



LK-1903BNB

Management, browsing and editing of data can be carried out on the application software

A "Two-way" contactless communication for parameter adjustment data can be conducted with the sewing machine by a commercial Android terminal. This feature allows sewing machines in a sewing line to be uniformly set and status checked quickly, thereby contributing to stabilization in product quality. Control panel is standardized with USB ports, promising simplicity in data management and system updates.

*Android OS Version 6.0 is recommended to use JUKI Smart APP. (Operation is confirmed with respect to Versions 5.0 and later.) Contact JUKI distributor in your area for how to use the application software.

 The sewing machine can be paired with equipment which supports NFC (Near Field Communication) only by holding the equipment over the sewing machine.



Model name	LK-1903BNB	LK-1903BN	LK-1903BN/BR35
Max. sewing speed	2,700sti/min		
Button size	Type: Round-shaped, flat button Size: $\phi 8 \sim \phi 20$ mm 301: $\phi 8 \sim \phi 20$	Type: Round-shaped, flat button Size: $\phi 8 \sim \phi 32$ mm 301 : $\phi 8 \sim \phi 20$ 302: $\phi 10 \sim \phi 20$ OPTION : $\phi 15 \sim \phi 32$	Type: Round-shaped, flat button (2-holed, 4-holed) Size: $\phi 9 \sim \phi 20$ mm For small button: $\phi 10 \sim \phi 15$ mm For medium-sized button: $\phi 12 \sim \phi 18$ mm (Those that are smaller than $\phi 10$ mm or larger than $\phi 18$ mm must be specially ordered.) Thickness: 1.8~3.5mm
Stitch length	0.1~10mm (0.1mm step)		
Lift of the work clamp foot	Max. 10mm	Max. 13mm	Max. 11mm
Number of standard patterns	34 patterns	50 patterns	
Number of data that can be input	200 patterns		
Needle	DPx17 (#11)	DPx17 (#14)	

Button Sewing Machine

Computer-controlled, High-speed, Lockstitch, Button Machine

LK-1903S

JUKI Simple Series sewing machine LK-1903S has been designed to have simplified and narrowed down capabilities that are essentially required to produce JUKI's established seam quality. In addition, it supports the operator with the voice guidance system to improve work efficiency.



LK-1903S

Model name	LK-1903S-SS
Max. sewing speed	2,700sti/min
Button size	Type : Round-shaped, flat button (2-holed, 4-holed) Size : $\phi 8 \sim \phi 32$ mm 301 : $\phi 8 \sim \phi 20$ 302 : $\phi 10 \sim \phi 20$ OPTION : $\phi 15 \sim \phi 32$
Lift of the work clamp foot	Max. 13mm
Needle (at the time of delivery)	DPx17 (#14)
Number of standard patterns	50 patterns
Number of data that can be input	200 patterns

Computer-controlled, Dry-head, High-speed, Single-thread, Chainstitch Button Sewing Machine

MB-1800A/BR10 (with button feeder)

MB-1800B (with wiper unit)

MB-1800S

The machine is able to independently sew various stitching shapes such as U-shaped stitching, X-shaped stitching and Z-shaped stitching. The machine has 55 different stitching patterns as standard. In addition to the sewing shapes, the buttonhole intervals and number of stitches can also be changed on the operation panel.



MB-1800A/BR10

Model name	MB-1800A/BR10	MB-1800B	MB-1800S
Max. sewing speed	1,800sti/min		
Amount of feed	Crosswise feed 0~4.0mm, Lengthwise feed 0~4.0mm	Crosswise feed 0~10mm, Lengthwise feed 0~6.5mm	
Applicable buttons	Type: Round-shaped flat buttons Size: $\phi 10 \sim \phi 18$ mm Size: $\phi 10 \sim \phi 28$ mm		
Stitching shape	□, -, X, Z, □, , +, -, △, ▽, <, ▷		
Button feed mode	Automatic feed mode, non-feed mode, and small-lot sewing mode	—	
Needle	TQx7 (#16) #14~#20		

Single-thread, Chainstitch, Button Sewing Machine (thread-fray-prevention ON/OFF changeover mechanism)

MB-1377 (quick stitch shape changing mechanism)

MB-1373

The machine is provided as standard with a "thread-fray-prevention ON/OFF changeover mechanism" to help produce beautiful seams with added durability. Stitch shape can quickly be changed over between X and □ button-hole configurations. (only for MB-1377)

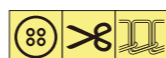

MB-1377

Model name	MB-1377	MB-1373
Max. sewing speed	1,500sti/min	
Number of stitches	8, 16, and 32 stitches	
Feed length (crosswise feed)	2.5~6.5mm	
Feed length (lengthwise feed)	0~4.5mm	0~6.5mm
Stitching shape	□, X, -	□, -
Applicable button	Shank button, Wrapped-around button, Snap, Label, Metal button, Stay button (exclusive attachments have to be used)	
Button size	$\phi 10 \sim \phi 28$ mm	
Thickness of button	1.8~3.5mm (options max. 5mm)	
Needle	TQx1 (#16) #14~20	

Buttonholing Machine

Computer-controlled, High-speed, Buttonholing Sewing System

LBH-1790ANB (shorter-thread remaining functions)

The newly-developed shorter-thread remaining mechanism trims the thread short and eliminates the trouble of manual thread nipping.



* Remaining length of thread varies with sewing conditions.

LBH-1790AN

The LBH-1790AN Series follows the world's highest sewing speed and dry-head mechanism of its predecessor model. In addition, this machine comes with the latest model operation panel which is installed with a USB port. Furthermore, all drive mechanisms have been digitalized to manage each sewing pattern individually. The maximum sewing speed is 4,200sti/min., and the jump speed is 200mm/s. The cycle time has been further reduced for continuous sewing.

LBH-1795AN (120mm presser type)

The knife supports sewing lengths of 41mm at the maximum. Since the LBH-1795ANS is provided as standard with the 120mm presser, it is capable of sewing 120mm long buttonholes. The LBH-1795ANS is capable of sewing long buttonholes such as belt holes in car seats. In addition, it is applicable to the sewing of buttonholes in men's shirts (continuous sewing of two buttonholes and the use of two units of sewing machines), etc.

LBH-1796AN (220mm presser type)

The LBH-1796AN is a subclass model of the LBH-1790AN Series. This product is provided with a 220mm work clamp foot. It follows the world's highest sewing speed, deeply recessed shape of the machine head and dry-head mechanism of the existing LBH-1790AN. In addition, the LBH-1796AN can also be used as a simplified indexer to sew three buttonholes in a row.



LBH-1790AN



LBH-1796AN

Management, browsing and editing of data can be carried out on the application software

A "Two-way" contactless communication for parameter adjustment data can be conducted with the sewing machine by a commercial Android terminal. This feature allows sewing machines in a sewing line to be uniformly set and status checked quickly, thereby contributing to stabilization in product quality. Control panel is standardized with USB ports, promising simplicity in data management and system updates.

*Android OS Version 6.0 is recommended to use JUKI Smart APP. (Operation is confirmed with respect to Versions 5.0 and later.) Contact JUKI distributor in your area for how to use the application software.

The sewing machine can be paired with equipment which supports NFC (Near Field Communication) only by holding the equipment over the sewing machine.



Model name	LBH-1790ANB	LBH-1790AN	LBH-1795AN	LBH-1796AN
Max. sewing speed	Max. 4,200sti/min, Normal 3,600sti/min When the non-lubricated hook (optional) is used: 3,300sti/min			
Size of cloth cutting knife	6.4~22.2mm (1/4"~7/8")	6.4~31.8mm (1/4"~1-1/4")		6.4~25.4mm
Bartacking width	Max. 4.0mm	Max. 5.0mm (with special-specification part: Max. 10mm)		Max. 5.0mm
Buttonhole length	Max. 25mm	Max. 41mm (optional: 70mm, 120mm)	Max. 120mm	Max. 220mm
Lift of the work clamp	14mm (17mm when the reverse-rotation needle-up function is used)			Parallel lifting 6mm
Number of standard patterns	31 patterns			
Number of patterns that can be input	Max. 99 patterns			
Needle	DPx5 (#11J) #11J~#14J			

Computer-controlled, High-speed, Buttonholing Machine

LBH-1790S

JUKI Simple Series sewing machine LBH-1790S has been designed to have simplified and narrowed down capabilities that are essentially required to produce JUKI's established seam quality. In addition, it supports the operator with the voice guidance system to improve work efficiency.

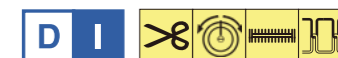

LBH-1790S

Model name	LBH-1790SS
Max. sewing speed	4,200sti/min (at the time of delivery: 3,600sti/min)
Size of cloth cutting knife	6.4~31.8mm (1/4"~1-1/4")
Buttonhole length	Max. 41mm
Needle (at the time of delivery)	DPx5 (#11J) #11J~#14J
Lift of the work clamp	14mm (17mm when the reverse-rotation needle-up function is used)
Number of standard patterns	31 patterns
Number of patterns that can be input	Max. 99 patterns

1-needle, Lockstitch Buttonholing Machine

LBH-780

Smooth operation contributes to high-quality finished buttonholes and a higher degree of efficiency.

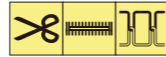

LBH-780

Model name	LBH-780
Max. sewing speed	3,600sti/min
Lift of the work clamp	Max. 12mm
Number of stitches	54~345 (by gear-change method)
Buttonhole length	6.4~38.1mm
Needle	DPx5 #11J, 134 Nm75

Computer-controlled, Eyelet Buttonholing Sewing System (Trimmer for Needle and Loper Thread with gimp)



MEB-3200CSS

(For men's and ladies' wear)

MEB-3200CRS

(For combined use for vertical and horizontal buttonholes: men's and ladies' wear)

MEB-3200CJS

(For jeans)

MEB-3200CCS

(For cotton pants and work pants)



MEB-3200CSS

The digitally controlled machine permits the selection and setting of various eyelet shapes. We thoroughly pursue operability and realized easy operation with a new operation panel. Control panel is configured with a large, highly visible color LCD touch panel for instant display of the stitch shape, set values, and menu settings for the sewing functions.

Model name	MEB-3200CSS	MEB-3200CRS	MEB-3200CJS	MEB-3200CCS
Application	Men's and ladies' wear	Combined use for lateral and longitudinal buttonholing: for men's and ladies' wear	Jeans	Cotton pants and working wear
Thread trimming style	Longer remaining thread		Shorter remaining thread	
Stitch system	1-needle, double chainstitch (with gimp)			
Max. sewing speed	400~2,200sti/min (100sti/min step)			
Sewing length	10~38mm (with thread trimmer) 10~50mm (in case looper thread trimming device is removed)*2	Work clamp type S 16~24 (26)mm: optional Work clamp type M 24~32 (34)mm: standard Work clamp type L 32~40 (42)mm: optional	Work clamp type S 16~24 (26)mm: standard Work clamp type M 24~32 (34)mm: optional Work clamp type L 32~40 (42)mm: optional	The figures in () parentheses are in case of taper bar
Needle throwing width (at the time of delivery)	2.0~3.2mm*2 (2.3mm)	2.6~4.0mm*3 (3.6mm)	2.0~3.2mm*3 (2.5mm)	
Taper bar length	0mm, 3~15mm			
Needle (at the time of delivery)	DOx558 (Nm100) Nm90~Nm110	DOx558 (Nm120) Nm120~Nm130	DOx558 (Nm110) Nm110~Nm120	

*1 When the sewing length of 38~50mm without thread trimmer is selected, the work clamp can be provided by placing special order. Please use the Multi-cutting device when you cut the cloth.
*2 By selecting the left looper and left spreader, the range of stitch bite can be changed to 2.6~4.0mm from 2.0~3.2mm (TS model is excluded)

Computer-controlled, Eyelet Buttonholing Sewing System (for jeans and cotton pants)



MEB-3900

The MEB-3900 reduces the machine time due to its maximum sewing speed of 2,500 sti/min and its speed-up cloth cutting knife, thereby demonstrating increased productivity. Then newly adopted direct-driven main shaft by means of a compact AC servomotor not only achieves enhanced responsiveness, but also achieves both reduced noise and reduced vibration. In addition, the machine has adopted an air-driven cloth cutting knife which promises excellent responsiveness and operates faster than the conventional knife.

Management, browsing and editing of data can be carried out on the application software

A "Two-way" contactless communication for parameter adjustment data can be conducted with the sewing machine by a commercial Android terminal. This feature allows sewing machines in a sewing line to be uniformly set and status checked quickly, thereby contributing to stabilization in product quality. Control panel is standardized with USB ports, promising simplicity in data management and system updates.



MEB-3900J

*Android OS Version 6.0 is recommended to use JUKI Smart APP. (Operation is confirmed with respect to Versions 5.0 and later.) Contact JUKI distributor in your area for how to use the application software.

N The sewing machine can be paired with equipment which supports NFC (Near Field Communication) only by holding the equipment over the sewing machine.

Model name	MEB-3900J	MEB-3900C
Application	Jeans	Cotton pants and working wear
Stitch system	1-needle, double chainstitch (with gimp)	
Sewing speed	400~2,500sti/min	
Stitch length	10~38mm (needle thread trimming type), 10~34mm (overall thread trimming type)	
Needle throwing width	Mechanical adjustment of the needle throwing width: 2.0~4.0mm Compensation of the needle throwing width (by the lower feed dog): 1.5~5.0mm	
Taper bar length	3~15mm	
Needle	D0x558 (Nm110) Nm90~Nm120	

Bartacking Machine

Computer-controlled, High-speed, Bartacking Sewing System



LK-1900BNB

(bird's nest preventing / shorter-thread remaining functions)

The sewing machine eliminates so-called "bird's nests" (thread tangling in on the wrong side of the material at the beginning of sewing). Length of thread remaining on the material at the end of sewing has been reduced to 2mm or less*.

*Remaining length of thread varies with sewing conditions.
*Use #60-80 (TEX22-30) polyester spun thread



Shorter-thread remaining

Finishing of the Bird's nest preventing / shorter-thread remaining functions (on the wrong side)

LK-1900BN

The machine achieves sewing speed of 3,200sti/min. The machine's starting, stopping, thread-trimming and automatic presser lifting speeds have been increased to significantly shorten total cycle time.

LK-1901BN (eyelet buttonholes)

The machine is provided with a material-drawing mechanism which draws the right and left parallel portions of an eyelet buttonhole near to one another. The machine performs bartacking with the right and left parallel portions of the eyelet buttonhole drawn near to one another after the buttonhole is clamped under the work clamp foot, thereby finishing highly durable and well-tensed eyelet buttonholes.

LK-1902BN (belt-loop-attaching)

The machine is provided as standard with six different linear bartacking patterns. Since the sewing size can be easily changed, the optimal number of stitches and sewing size can be speedily selected according to the belt-loop width. If the normally used patterns are assigned to the patterns keys, a desired pattern can be called up or changed with single-key operation.

LK-1900BNSS000/X75024

This machine is a special model that expands the sewing area to 50mm (W) x 50 (L) mm. It corresponds to the sewing size such as the elastictape connection of the boxer pants, the box sewing of the sleeve spread, and the attach the Velcro.

*The presser foot of this machine is equipped with the standard presser foot (40mm(W) x 30mm(L)). Please arrange the presser foot as necessary.



LK-1900BNB



LK-1901BN



LK-1902BN

Management, browsing and editing of data can be carried out on the application software

A "Two-way" contactless communication for parameter adjustment data can be conducted with the sewing machine by a commercial Android terminal. This feature allows sewing machines in a sewing line to be uniformly set and status checked quickly, thereby contributing to stabilization in product quality. Control panel is standardized with USB ports, promising simplicity in data management and system updates.



*Android OS Version 6.0 is recommended to use JUKI Smart APP. (Operation is confirmed with respect to Versions 5.0 and later.) Contact JUKI distributor in your area for how to use the application software.

The sewing machine can be paired with equipment which supports NFC (Near Field Communication) only by holding the equipment over the sewing machine.

Model name	LK-1900BN-SS	LK-1900BN-HS	LK-1900BN-FS	LK-1900BN-MS	LK-1900BN-WS
Application	Standard	For heavy-weight materials	For foundation	For knits and knitted materials	With large hook for heavy-weight materials
Max. sewing speed	3,200sti/min				2,700sti/min
Sewing area	30mm (L) x 40mm (W)				
Stitch length	0.1~10mm (0.1mm step)				
Lift of the work clamp foot	Standard 14mm (17mm when the reverse-rotation needle-up function)				
Number of stitches that can be stored in memory	Max. 20,000 stitches				
Number of standard patterns	51 patterns				
Number of data that can be input	200 patterns				
Needle	DPx5 (#14)	DPx17 (#21)		DPx5 (#11)	DPx17 (#21)

Model name	LK-1900BN-BS	LK-1900BN-BF	LK-1901BN-SS	LK-1902BN-SS	LK-1902BN-HS
Application	Standard	For foundation	Standard	Standard	For heavy-weight materials
Max. sewing speed	3,200sti/min		3,000sti/min		
Sewing area	30mm (L) x 40mm (W)				
Stitch length	0.1~10mm (0.1mm step)				
Lift of the work clamp foot	Standard 11mm (by using the reverse-rotation needle-up function 14mm)		Standard 14mm (17mm when the reverse-rotation needle-up function)		
Number of stitches that can be stored in memory	Max. 20,000 stitches				
Number of standard patterns	50 patterns		—		
Number of data that can be input	200 patterns (for up to 150 patterns, sewing data can be added.)		200 patterns		
Needle	DPx17 (#14)	DPx17 (#11)		DPx5 (#14)	DPx17 (#21)

Bartacking Machine

Computer-controlled, High-speed, Bartacking Machine



LK-1900S

JUKI Simple Series sewing machine LK-1900S has been designed to have simplified and narrowed down capabilities that are essentially required to produce JUKI's established seam quality. In addition, it supports the operator with the voice guidance system to improve work efficiency.

LK-1900SS000/X75023

This machine is a special model that expands the sewing area to 50mm (W) x 50 (L) mm. It corresponds to the sewing size such as the elastictape connection of the boxer pants, the box sewing of the sleeve spread, and the attach the Velcro.

*The presser foot of this machine is equipped with the standard presser foot (40mm(W) x 30mm(L)). Please arrange the presser foot as necessary.



LK-1900S

Model name	LK-1900S-SS	LK-1900S-HS
Application	Standard	For heavy-weight materials
Max. sewing speed	3,200sti/min (at the time of delivery: 2,700sti/min)	
Sewing area	30mm (L) x 40mm (W)	
Stitch length	0.1~10mm (0.1mm step)	
Lift of the work clamp foot	Standard 13mm (17mm when the reverse-rotation needle-up function)	
Needle (at the time of delivery)	DP x 5 (#14)	DP x 17 (#21)
Number of stitches that can be stored in memory	Max. 20,000 stitches	
Number of standard patterns	51 patterns	
Number of data that can be input	200 patterns	

Shape-tacking Machine

Computer-controlled, High-speed Shape-tacking Machine

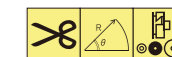

LK-1910

LK-1920 (with intermediate presser)

The sewing speed of 2,500 sti/min is the fastest-level sewing speed among the shape-tacking machines. The sewing machine has adopted a semi-rotary two-fold capacity hook. In addition, the sewing machine comes with enhanced functions such as the feeding frame with a higher lift and the direct-drive machine head that provides excellent responsiveness and stop accuracy support the machine's high-speed performance, thereby achieving increased productivity.



LK-1920

Model name	LK-1910S, 20S	LK-1910H, 20H
Application	Standard	Heavy-weight
Sewing area	60mm (L) x 100mm (W)	
Max. sewing speed	2,500sti/min	
Stitch length	0.1~10mm	
Number of data that can be input	64 patterns	
Needle	DPx5 (#14)	DPx17 (#18)

Computer-controlled Cycle Machine with Input Function



AMS-221F-2516
(X: 250mm x Y: 160mm)
AMS-221F-3020
(X: 300mm x Y: 200mm)

AMS-221F has achieved increased productivity with its maximum sewing speed of 2,800 sti/min and beautifully finished seams with its new feed control system. The active tension can be changed over with the memory switch between the low-tension side output and the high-tension side output to enable fine adjustment of the thread tension in the actual area of use.



AMS-221F-2516

Management, browsing and editing of data can be carried out on the application software

A "Two-way" contactless communication for parameter adjustment data can be conducted with the sewing machine by a commercial Android terminal. This feature allows sewing machines in a sewing line to be uniformly set and status checked quickly, thereby contributing to stabilization in product quality. Control panel is standardized with USB ports, promising simplicity in data management and system updates.



*Android OS Version 6.0 is recommended to use JUKI Smart APP. (Operation is confirmed with respect to Versions 5.0 and later.) Contact JUKI distributor in your area for how to use the application software.

The sewing machine can be paired with equipment which supports NFC (Near Field Communication) only by holding the equipment over the sewing machine.

Model name	AMS-221F-S	AMS-221F-H	AMS-221F-G
Application	Light- to medium-weight	Medium- to heavy-weight	Heavy- to Extra heavy-weight
Max. sewing speed	2,800sti/min		
Sewing area	0.1~12.7mm (0.05mm step)		
Storage of pattern data in the memory	Main-body memory: Max. 50,000,000 stitches, 999 patterns (max. 50,000 stitches / pattern)		
	External media: Max. 50,000,000 stitches, 999 patterns (max. 50,000 stitches / pattern)		
Needle	DPx5 (#14)	DPx17 (#18)	DPx17 (#23)

Computer-controlled Cycle Machine with Input Function



AMS-210EN-1306 (X: 130mm x Y: 60mm)
AMS-210EN-1510 (X: 150mm x Y: 100mm)
AMS-210EN-2210 (X: 220mm x Y: 100mm)
AMS-221EN-2516 (X: 250mm x Y: 160mm)
AMS-221EN-3020 (X: 300mm x Y: 200mm)

The sewing machine achieves the highest sewing speed, 2,800sti/min, in the industrial sewing machine industry. As a result, cycle time is dramatically reduced. The feed accuracy is substantially improved due to the adoption of the encoder control system. The new AMS Series models substantially decrease power consumption when compared with the conventional ones. They have been designed to achieve eco-friendliness.

AMS-210EN-1306 (X: 130mm x Y: 60mm)

The sewing machine flexibly supports the sewing of small articles such as labels and emblems. The sewing machine's small sewing area promises ease of use when handling small articles, thereby enabling smooth sewing operation.

AMS-210EN-1510 (X: 150mm x Y: 100mm)

The 1510 model is well received in the market due to its moderate-sized sewing area. Responding to market demand, the 1510 area model with a motor-driven feeding frame has been newly developed. This model can be used in a plant which is not provided with pneumatic equipment.

AMS-210EN-2210 (X: 220mm x Y: 100mm)

This model has a sewing area that is best-suited to the sewing of large parts, including the shape-tacking of jean pockets. With this model, you may recognize the higher productivity of the cycle machine.



AMS-210EN-1510

AMS-221EN-2516 (X: 250mm x Y: 160mm)

The sewing machine is best-suited to the sewing of large labels and emblems, the sewing of two or more pieces of small labels and emblems at one time, and the shape-tacking of bags and shoes. The sewing machine is applicable to a broad range of materials and processes, while leading the industrial sewing machine industry in terms of improvement in quality and the promotion of production that does not require sewing-machine operators to have special skills.

AMS-221EN-3020 (X: 300mm x Y: 200mm)

The sewing machine is applicable to sewing products which require a wider sewing area than that of the "AMS-221EN-2516." It is best-suited to the attaching of handles to bags and the shape-tacking of boots and shoes. The sewing machine is flexibly applicable to sewing requiring a medium sewing area.



AMS-221EN-2516

Model name	AMS-210EN-SS	AMS-210EN-HS	AMS-221EN-SL	AMS-221EN-HL
Application	Light- to medium-weight	Medium- to heavy-weight	Light- to medium-weight	Medium- to heavy-weight
Max. sewing speed	2,800sti/min			
Stitch length	0.1~12.7mm (0.05mm step)			
Storage of pattern data in the memory	Main-body memory: Max. 500,000 stitches, 999 patterns (max. 50,000 stitches / pattern)			
	External media: Max. 50,000,000 stitches, 999 patterns (max. 50,000 stitches / pattern)			
Needle	DPx5 (#14)	DPx17 (#18)	DPx5 (#14)	DPx17 (#18)

*Stitch length is 4mm or less for the AMS-210EN and 3.5mm or less for the AMS-221EN.

Computer-controlled Cycle Sewing Machine with Input Function (name embroidery type)

AMS-210EN-1306/7450

This is the name (alphabetic/Japanese/Chinese characters) embroidering machine which achieves the embroidering-machine industry's highest sewing speed of 2,000sti/min. The sewing machine is a computer-controlled cycle machine provided with an input function. Once the operator places a piece of material on the sewing machine, the sewing machine carries out the entire sequence of embroidering according to the preliminarily input name data from start to the thread trimming under finish in a fully-automatic manner. With this function, the machine enables even an inexperienced operator to beautifully and speedily embroider names with accuracy.

Model name	AMS-210EN-1306/7450
Application	Standard (light- to medium-weight)
Max. sewing speed	2,000sti/min
Sewing area	X: 130mm x Y: 60mm
Stitch length	0.1~12.7mm (0.05mm step)
Storage of pattern data in the memory	Main-body memory: Max. 500,000 stitches, 999 patterns (max. 50,000 stitches / pattern) External media: Max. 50,000,000 stitches, 999 patterns (max. 50,000 stitches / pattern)
Needle	DPx17 (#11)



AMS-210EN-SS1306SA/7450

Computer-controlled Cycle Sewing Machine with Input Function (for shape-tacking of jean pockets)

AMS-210ENHL-2210/X90003

Even an inexperienced operator is able to sew shape-tacking of jean pockets only by placing a pocket piece on the sewing machine and carrying out the start operation. Pattern can be changed without using a tool in the case of changing the design, sewing size, etc.

- The possible pocket stitching range is 220 mm (W) x 100 mm (L).
- The stacker is provided for the sewing machine as standard and is able to stack 50 pockets.

Model name	AMS-210ENHL-2210/X90003
Application	Medium- to heavy-weight
Max. sewing speed	2,800sti/min
Pocket size	110~220mm (W) x 110~230mm (L)
Needle	DPx17 (#18)
Thread	#50~#2



AMS-210ENHL-2210/X90003

Computer-controlled Cycle Sewing Machine with Input Function (polo-shirts placket device) (Single Placket with Top stitch type for mens) (Dubble Placket type for mens) (Single Placket with Top stitch type / Dubble Placket type for mens)

AMS-221ENHS-3020

The machine fully automatizes a series of sewing placket processes. The machine carries out a series of placket setting processes at 21 sec/pcs (Single Placket). It achieves 4.7 times as productive as general-purpose machines. This device is able to place a placket on garment body while the machine is still engaged in the sewing of the current placket. This means higher productivity can be achieved simply with one machine.

- The machine can sew V-shape stitch, and Dimple-shaped depression by automatic is fewer than by manual work.
- Topstitch is produced at the place 1.5mm to 3.0mm from the edge of the under placket.

Model name	AMS-221ENHS-3020/Polo-shirts Placket Device		
Description	Single Placket with Top stitch type	Dubble Placket type	Single Placket with Top stitch type / Dubble Placket type
Application	Medium weight		
Max. sewing speed	2,500sti/min		
Needle	135x17(No. 65~75), DPx17 (#9~#11)		
Sewing area	4~6mm(W) x less than 200mm(L)	20~50mm(W) x less than 200mm(L)	
Placket material size	90~130mm(W) x less than 235mm(L)	48~113mm(W) x less than 235mm(L)	



AMS-221ENHS-3020

Computer-controlled Cycle Sewing Machine with Input Function (Polo-shirts placket with Transport device)

AMS-221ENHS-3020/X90014 (Single Placket with Top stitch type for mens)

AMS-221ENHS-3020/X90026 (Double Placket for mens)

- It is an automatic machine equipped with a transport device to reduce operator's work in polo-shirts placket process. Just by setting the placket with pedal operation and push button, sewing can be done. It is equipped with stacker, we will stack the finished products automatically on the stacker table.
- It achieves 5.2 times as productive as general-purpose machines. (for Single type)

Model name	AMS-221ENHS-3020/X90014	AMS-221ENHS-3020/X90026
Application	Medium weight	
Max. sewing speed	2,500sti/min	
Needle	135x17(No. 65~75), DPx17 (#9~#11)	
Sewing area	4~6mm(W) x less than 200mm(L)	20~50mm(W) x less than 200mm(L)
Placket material size	90~130mm(W) x less than 235mm(L)	48~113mm(W) x less than 235mm(L)



AMS-221ENHS-3020/X90014

Computer-controlled Cycle Sewing Machine with Input Function (for sewing pockets on jeans) (with presetting device)

AMS-221ENHS-3020/X90005, X90006 AMS-221ENTS-3020/X90002, X90004 (2-color-thread sewing)

This model is designed for sewing pockets on jeans and is based on the AMS-221EN Series.

- The machine sews folded pocket cloth on the garment body.

Model name	AMS-221ENHS-3020 /X90005,X90006	AMS-221ENTS-3020 /X90002,X90004
Application	With presetting device	2-color-thread sewing · With presetting device
Max. sewing speed	2,500sti/min	
Sewing area	Max. 110mm x 110mm Min. 90mm x 90mm	
Stitch length	0.1~12.7mm (0.05mm step)	
Storage of pattern data in the memory	Main-body memory: Max. 500,000 stitches, 999 patterns (max. 50,000 stitches / pattern) External media: Max. 49,950,000 stitches, 999 patterns (max. 50,000 stitches / pattern)	
Needle	DPx17 (#21) #18~#21	



AMS-221ENTS-3020/X90002

Computer-controlled Cycle Machine with Input Function (for sewing pockets on jeans)

AMS-221ENHS-3020/7200

This model is designed for sewing pockets on jeans and is based on the AMS-221EN Series.

- The machine sews folded pocket cloth on the garment body.
- Maximum stitching range of a pocket that can be sewn is 246mm (width) x 200mm (length).

Model name	AMS-221ENHS-3020/7200
Application	Heavy-weight
Max. sewing speed	2,000sti/min
Sewing area	X: 246mm x Y: 200mm
Stitch length	0.1~12.7mm (0.05mm step)
Storage of pattern data in the memory	Main-body memory: Max. 500,000 stitches, 999 patterns (max. 50,000 stitches / pattern) External media: Max. 49,950,000 stitches, 999 patterns (max. 50,000 stitches / pattern)
Needle	DPx17 (#19)



AMS-221ENHS-3020/7200

Computer-controlled Cycle Machine

Computer-controlled Cycle Machine with Input Function (for J stitch)

AMS-221ENTS-3020/X90013 (2-color-thread sewing)

This model is designed for topstitching front fly on jeans etc and is based on the AMS-221EN Series. High quality and no need skill J Stitch automatic machine. It can correspond to various sewing patterns, it prevents displacement by the vacuum device.

Model name	AMS-221ENTS-3020/X90013
Application	Heavy-weight
Max. sewing speed	2,500sti/min
Sewing area	X: 280mm x Y: 100mm
Stitch length	0.1~12.7mm (0.05mm step)
Storage of pattern data in the memory	Main-body memory: Max. 500,000 stitches, 999 patterns (max. 50,000 stitches / pattern)
	External media: Max. 49,950,000 stitches, 999 patterns (max. 50,000 stitches / pattern)
Needle	DPx17 (#19)



AMS-221ENTS-3020/X90013

Computer-controlled Cycle Machine with Input Function

AMS-224EN-4530 (X: 450mm x Y: 300mm)

AMS-224EN-6030 (X: 600mm x Y: 300mm)

The machine achieves the highest sewing speed of 2,500sti/min among those with a similar sewing area. With its higher productivity, the machine performs various kinds of stitching, making the most out of its wider sewing area in various sewing applications such as attaching handles to bags and pouches, attaching belts, sewing many small parts at a time, attaching parts to shoes and sports shoes (one pair of shoes) and sewing air bags.



AMS-224EN-6030

Model name	AMS-224EN-HS	AMS-224EN-GB
Application	Medium- to heavy-weight	Extra heavy-weight
Max. sewing speed	2,500sti/min (stitch length 3mm or less)	
Settable stitch length	0.1~12.7mm (0.05mm step)	
Storage of pattern data in the memory	Main-body memory: Max. 500,000 stitches, 999 patterns (max. 50,000 stitches / pattern)	
	External media: Max. 50,000,000 stitches, 999 patterns (max. 50,000 stitches / pattern)	
Needle	DPx17 (#18)	DPx17 (#23)

Automatic Bobbin Thread Wind-and-Feed Device (Retrofit Kit for AMS-EN Series Shuttle Hook Machine)

AW-3S

This is Automatic Bobbin Thread Wind-and-Feed Device that can be retrofitted to the computer-controlled cycle machine with a semi-rotary hook, AMS-221EN and AMS-224EN. Improved seam quality, productivity and operability are achieved by installing this device to the sewing machine! This device is suitable for the sewing of products such as air bags, sports shoes and bags.

Device	AW-3S
Sewing machine head to which the device is installed	AMS-221EN / AMS-224EN (sewing machine head with a semi-rotary hook)
Applicable bobbin and bobbin case	Exclusive bobbin and bobbin case
Thread	#5~#30, 135~45(TEX), 020~060(TKT)
Applicable types of thread	Tetoron thread, nylon thread
Remaining thread removal operation, bobbin winding and threading operations	Automatic (while the sewing machine is in operation)



Example of installation of AW-3S retrofitted

AMS-221EN

Automatic Machine

Lockstitch, Automatic Welting Machine

APW-895NS (for straight pockets with flaps)

APW-895NL (for straight pockets with flaps, long and wide type)

APW-896NS (for slanted pockets with flaps)

The machine supports the sewing of straight pockets (with flaps) on suits, jackets and pants. Double-/single-welt sewing can be changed over by the simple touch of a key on the operation panel.

- The "direct-drive motor", which transfers the motor power to the machine with no energy loss, not only offers economical benefits due to the power reduction, but also reduces the machine's vibration and operating noise, thereby helping reduce operator fatigue.
- The machine head is provided with a semi-dry head to eliminate staining with oil from the frame (the needle bar part).
- The support of long and wide welts is enriched, the machine can sew large-sized pockets such as pockets on coats.

(APW-896NS)

In addition to the APW-895N's functions, the APW-896NS supports the sewing of slanted pockets (for sewing slanted flaps). The world's first computer-controlled sidewise cutting position of the corner knives enables easy adjustments of the knives simply by operating the panel.



APW-896N

Model name	APW-895N	APW-896N
Flap type	Rectangular flap	Rectangular / Slanted flap
Sewing speed	Max. 3,000sti/min (1,000~3,000sti/min)	
Kind of welts	Parallel double welt, parallel single welt (with / without flaps)	Parallel double welt, parallel single welt, slanted double welt, slanted single welt, trapezoidal sewing (with / without flaps)
Stitch length	Standard 2.5mm (2.0~3.4mm)	
Stitch length (fastening stitching)	Condensation stitching: Standard 1.0mm (0.5~1.5mm) Back-tack stitching: Standard 2.0mm (0.5~3.0mm) *Changeable between condensation / back-tack stitching	
Corner-knife cutting adjusting method	Mechanical adjustment	Electronic adjustment
Needle	ORGAN DPx17 Standard #16 (#14~#18), SCHMETZ 190R Standard #100 (#100~#110)	
Number of independent sewing patterns	99 patterns (999 patterns when a CF memory card is used)	
Number of cycle sewing patterns	20 patterns	
Number of alternate sewing patterns	20 patterns	

Model name	With / Without (corner knife and center knife)	Sewing length (welt length)	Needle gauge (mm)
APW-895NS	Without	Min. 18mm~Max. 220mm (settable in increments of 0.1mm)	8, 10, 12, 14, 16, 18, 20
	With	Min. 35mm When a solenoid valve is used: Min. 21mm *For a needle gauge width of 14mm or more, the minimum sewing length is 50mm.	
APW-895NL	Without	Min. 18mm~Max. 300mm (settable in increments of 0.1mm)	22, 24, 26, 28, 30, 32
	With	Min. 50mm~Max. 250mm (settable in increments of 0.1mm)	
APW-896NS	Without	Min. 18mm~Max. 220mm (settable in increments of 0.1mm)	8, 10, 12, 14, 16, 18, 20
	With	Needle gauge 12mm or less: Min. 21mm~Max. 220mm Needle gauge 14mm or more: Min. 50mm~Max. 220mm	

Lockstitch Automatic Welting Machine (for straight pockets without flaps)

APW-895NE (Economy type)

APW-895NE provides excellent performance and high productivity in welting, such as slacks and working pants. It comes with a high-speed machine head that is able to perform sewing at 3,000 sti/min at the maximum. Even an inexperienced operator can easily sew slacks and working pants by just placing the fabric on the welting machine and carrying out the start operation.

Model name	APW-895NE
Sewing speed	Max. 3,000 sti/min
Kind of welts	Parallel double welt, parallel single welt(without flaps)
Stitch length	Standard 2.5mm (2.0~3.4mm)
Stitch length (fastening stitching)	Condensation stitching: Standard 1.0mm (0.5~1.5mm) Back-lack stitching: Standard 2.0mm (0.5~3.0mm) *Changeable between condensation / back tack stitching
Corner-knife cutting adjusting method	Mechanical adjustment
Needle	DP x 17 Standard #16 (#14~#18), 190R Standard #100 (#100~#110)
Number of independent sewing patterns	99 patterns (999 patterns when a CF memory card is used)
Number of cycle sewing patterns	20 patterns
Number of alternate sewing patterns	20 patterns



APW-895NE

Model name	With / Without (corner knife and center knife)	Sewing length (welt length)	Needle gauge (mm)
APW-895NE (Economy type)	Without	Min. 18mm~Max. 220mm (settable in increments of 0.1mm)	10, 12
	With	Min. 35mm When a solenoid valve is used: Min. 21mm *For a needle gauge width of 14mm or more, the minimum sewing length is 50mm.	

Jeans Pocket Setter

AP-876 (full-automatic)

The machine automatizes a series of pocket setting processes such as the folding of a pocket, placement of the pocket on a garment body, sewing, bartacking and stacking, thereby increasing productivity and achieving production without requiring the operator to have any special skill. This promises consistent finished quality.

AP-874 (semi-automatic)

This sewing machine is a semi-automatic type pocket setter. The sewing machine has been specifically designed for sewing pockets which have been preliminarily folded in the preceding process on a predetermined location of the garment body without folding the pocket cloths.

Model name	AP-876	AP-874
Application	Full-automatic	Semi-automatic
Machine head	High-speed, 1-needle, lockstitch, zigzag stitching machine (exclusive machine head)	
Max. sewing speed	4,000sti/min	
Sewing area	250mm x 250mm	
Stitch length	0.1~6mm	
Operation panel	IP-420 (large-sized color liquid crystal touch panel)	
Storage of pattern data in the memory	Max. 999 pattern	



AP-876S

Automatic 1-needle Belt-Loop Attaching Machine

AB-1351

AB-1351 is belt-loop attaching machine with the ability to solely sew 12 different belt-loop sewing patterns! This machine not only reduces the time required for the belt-loop attaching process, but also achieves labor-saving, such as the elimination of the previous process (belt-loop cutting). Productivity can be dramatically increased when one operator attends to two AB-1351 units.

Model name	AB-1351
Machine head	LK-1961/ABH (Exclusive machine head based on the LK-1900A, Semi-dry-head)
Max. sewing speed	2,500sti/min
Stored bartacking patterns (Stitches)	Linear bartacking (12, 15, 21, 28, 36, 41) / Zigzag bartacking (28, 36, 42, 56, 64)
Bartacking size length-wise	0~3.2mm (0~1/8") (adjustable in increments of 0.1mm)
Bartacking size cross-wise	6~23mm (15/16"~57/64") (adjustable in increments of 0.1mm)
Needle	DPx17 #14, 135x17 #90
Thread	Spun 80Nm (recommend), Filament 80Nm (80Nm=#50)
Belt-loop width	8~20mm (5/16"~25/32")



AB-1351

Automatic 2-needle Belt-loop Attaching Machine

MOL-254

The machine time is 1.2 seconds per belt-loop, which ensures increased productivity. The feed mechanism incorporates a computer-controlled X-Y method to allow the operator to change the number of stitches and sewing sizes.

Model name	MOL-254
Max. sewing speed	2,500sti/min
Number of stitches	28, 36, 42 (selectable on the operating panel)
Needle gauge	40~70mm (1-37/64"~2-3/4")
Bartacking length	7~22mm (9/32"~55/64") (adjustable in increments of 0.1mm)
Bartacking width	1~3.2mm (3/64"~1/8") (adjustable in increments of 0.1mm)
Belt-loop width	9~20mm (23/64"~25/32")
Finished length of belt-loop	48~78mm (1-57/64"~3-5/64")
Needle	DPx17 (#21) #19~#21



MOL-254

Computer-controlled, High-speed, Single-thread Chainstitch, Button-neck-wrapping Machine

AMB-289

The machine demonstrates the highest productivity among button-neck-wrapping machines intended for men's and ladies' outer wear. A single machine unit permits the quick changeover of types of buttons to be sewn, i.e., flat buttons, shank button, marble buttons and stay buttons with a one-touch utility lever.

Model name	AMB-289
Max. sewing speed	1,800sti/min (neck-wrapping), 1,200sti/min (button sewing)
Button size	Sewing button without neck-wrapping: $\phi 8 \sim \phi 38$ mm Sewing button with neck-wrapping: $\phi 8 \sim \phi 32$ mm Counter button: $\phi 8 \sim \phi 25$ mm
Setting data	Distance between buttonholes: 1.5~6mm (0.1mm step) Height of neck-wrap: 0, 1.5~10mm
Number of data that can be input	Max. 99 patterns
Needle	SMx332EXTLG-NY (#14) #12~#18



AMB-289

High-speed, Computer-controlled Buttonholing Indexer

AC-172N-1790AN

LBH-1790AN, high-speed, computer-controlled lockstitch buttonholing machine has been combined with a high-performance and highly accurate indexer.

- "Applicability to vertical stripe patterns has been improved." The newly-developed sub-clamp mechanism prevents slippage of the material to enable accurate and consistent buttonholing.
- "Increased productivity achieved by the preset mechanism"

Model name	AC-172N-1790AN
Machine head	LBH-1790AN (exclusive machine head for AC)
Max. sewing speed	4,200sti/min
Sewing dimension	Standard : Width 4mm x length 25mm (max: width 6mm x length 120mm by replacing parts)
Knife size	6.4~19.1mm (1/4"~3/4" inch)
Feed direction	Right (for men's garments) or left (for ladies' garments)
Number of patterns that can be input	20 patterns
Number of buttonholes	1~20 pcs.
Needle	DPx5 #11J~#14J



AC-172N-1790AN

*The CE type sewing machine is AC-172N-1790.

Automatic Serging Machine

ASN-690

Increased productivity is required in the serging process. JUKI has launched its super-high speed machine developed in pursuit of simple-in-operation and ease-of-use. To fully support the operator so that he/she can carry out serging speedily, the machine comes in two different types; the long-table type and the short-table type which permits easy handling of the material.



ASN-690L

Model name	ASN-690
Machine head	MO-6904S (super-high-speed, 1-needle overlock machine)
Application	Serging of skirts, pants, jeans, etc.
Max. sewing speed	8,000sti/min
Stitch length	0.8~4mm
Overedging width	4.0, 4.8, 5.6mm
Differential feed ratio	For gathering 1:2 (max. 1:4), For stretching 1:0.7 (max. 1:0.6)
Needle	DCx27 (#11) #9~#14

Edge Control Seamer

AE-200ANLA (Join materials type)
AE-200ANLD (Pin tuck type)

AE-200AN is configured with JUKI's unique sensor and manipulator-control mechanisms allowing inexperienced operators to join materials with different curves with great finesses matching the finished seam quality of highly skilled operators. Large color LCD touch panel IP-420 is adopted. Sewing specifications can be quickly and accurately adjusted via touch panel to meet the requirement of various design changes and which helps operators join materials nimbly and skillfully while enhancing productivity even in sewing processes for custom-designed articles in small lots.

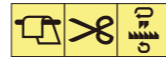

AE-200ANLA

Model name	AE-200ANLA	AE-200ANLD
Application	Join materials type (medium-weight)	Pin tuck type
Machine head	DLU-5498N-7 (exclusive machine head for AE-200A)	
Sewing speed	200~3,500sti/min	
Max. stitch length	4mm	
Max. top-feed amount	8mm	
Lift of the presser foot	10mm	
Needle	DPx1 (#11) #9~#18	
Sewing condition	(Seam allowance) 1~30mm, (Curve sewing) 100mmR or more (Number of plies) Two or one	

Needle Bar Rotation 360° Pattern Seamer

PS-900-13090
(X: 1,300mm x Y: 900mm)



The dry head machine achieves max speed 3,000 sti/min.
The needle bar rotation mechanism uses JUKI's unique synchronization technology to control the machine needle bar, hook, and feed to create optimal stitches.
The world's first active tension for turning needle bar is used for the needle thread tension controller.



PS-900SB13090CKZ

Model name	PS-900SB13090CKZ PS-900SB13090CKW	PS-900SB13090ZKZ PS-900SB13090ZKW
Sewing area	1,300mm x 900mm	
Max. sewing speed	3,000sti/min	
Lubrication	Semi-dry	
Feeding type	Belt drive	
Stitch length	0.5 — 12.7 mm	
Cutter equipment	Laser	—
Needle	DB x 1 #8 (7#~14#)	
Dimensions	2,100mm (W) x 2,325mm (L) x 1,240mm (H)	

Pattern Seamer

PS-800-13085
(X: 1,300mm x Y: 850mm)
PS-800-12080
(X: 1,200mm x Y: 800mm)
PS-800-8045
(X: 800mm x Y: 450mm)
PS-800-6045
(X: 600mm x Y: 450mm)



The dry head machine achieves max. speed 3,000sti/min with supporting various sewing and materials. There are 4 types of sewing areas. The PS-800-8045 can be installed in a space-saving manner. Not only the parts department but also sewing lines can be used.



PS-800-12080

Model name	PS-800SB13085	PS-800HB13085	PS-800SB8045	PS-800HB8045	PS-800SB6045	PS-800SS12080	PS-800HS12080
Sewing area	1,300 mm x 850 mm		800 mm x 450 mm		600 mm x 450 mm		1,200 mm x 800 mm
Feeding type	Double stepping motor Belt Drive					Screw drive (ball screw)	
Max. sewing speed	3,000 sti/min						
Stitch length	0.5 - 12.7 mm						
Needle	DB x 1 #8 (7#~14#)	DP x 17 #21 (18#~23#)	DB x 1 #8 (7#~14#)	DP x 17 #21 (18#~23#)	DB x 1 #8 (7#~14#)		DP x 17 #21 (18#~23#)
Dimensions	2,190mm (W) x 2,100mm (L) x 1,250mm (H)		1,200mm (W) x 1,325mm (L) x 1,250mm (H)		1,560mm (W) x 1,200mm (L) x 1,250mm (H)		2,180mm (W) x 2,185mm (L) x 1,250mm (H)

Automatic Machine

Pattern Seamer

PS-800SB-8045CKZ/X88011

(X: 800mm x Y: 450mm)

This machine is a special model modified for Welting. The dry head machine achieves max. speed 3,000sti/min with supporting various sewing and materials. The PS-800-8045 can be installed in a space-saving manner. The table size width is 1,200mm, the same as 1-needle lockstitch machine.



PS-800SB-8045CKZ/X88011

Model name	PS-800SB-8045CKZ/X88011
Sewing area	X: 800mm x Y: 450mm
Feeding type	Double stepping motor Belt Drive
Max. sewing speed	3,000 sti/min
Stitch length	0.5 - 12.7 mm
Needle	DB x 1 #8 (7#~14#)
Dimensions	1,200mm (W) x 1,325mm (L) x 1,250mm (H)

Pattern Seamer

PS-800-2850

(X: 280mm x Y: 500mm)

The dry head machine achieves max speed 3,500 sti/min. PS-800SB-2850ZKVV is equipped with a vacuum device that facilitates the setting of soft knits and light fabrics. The machine can be installed in a space-saving manner. Not only the parts department but also sewing lines can be used.



PS-800SB-2850ZKVV

Model name	PS-800SB-2850ZKZV PS-800SB-2850ZKVV	PS-800SB-2850ZKZ PS-800SB-2850ZKW
Sewing area	280mm x 500mm	
Max. sewing speed	3,500sti/min	
Lubrication	Semi-dry	
Fabric Vacuum Function	Standard	No (OP device can be retrofitted)
Thread trimmer	Double blades drive rotary knife type thread trimmer	
JaNets device	Retrofittable	
Dimensions	1,060mm (W) x 1,330mm (L) x 1,250mm (H)	



Automatic Machine

Pattern seamer (X:1,200mm x Y:700mm)

PS-700

This is a pattern seamer provided with JUKI's first exclusive machine head. It is able to carry out pattern sewing of large products with flexibility. The PS-700 has achieved the industry's highest jump speed of 800 mm/s.

The auxiliary clamp holds down the cassette clamp and material, thereby securely holding the material being sewn.



PS-700

Model name	PS-700
Max. sewing speed	3,000sti/min
Sewing area	X 1,200mm x Y 700mm
Needle thread tension	Active tension (electronic thread tension control mechanism)
Hook	Full-rotary double-capacity hook



Software / System

Programming Software for Computer-controlled Sewing Machines

PM-1

This software is to input and edit sewing data of JUKI's latest sewing machines.

Its versatile input functions allow to input sewing data of each electronic sewing machine model easily, accurately, and quickly.

It supports high quality production with high added value by utilizing and creating original data for specific designs and applications.

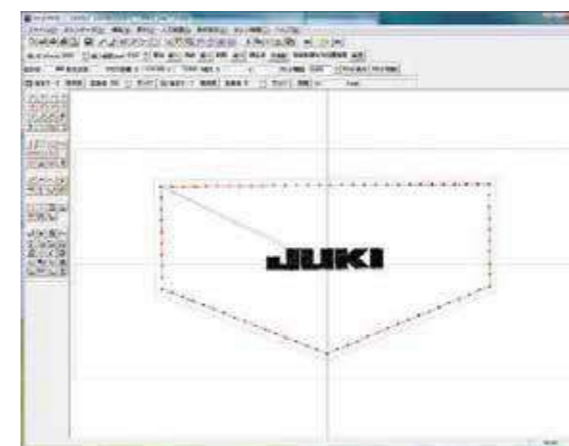

System Formation

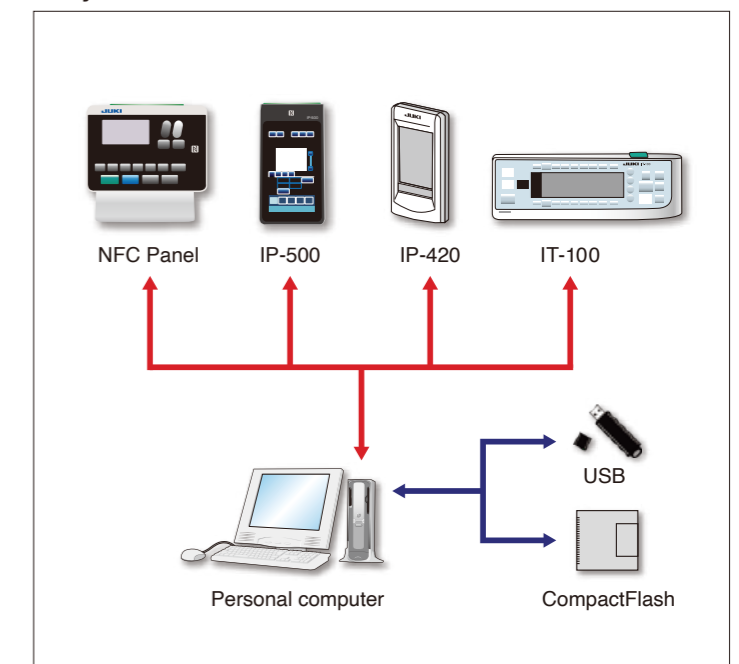

The sewing machine can be paired with equipment which supports NFC (Near Field Communication)



CompactFlash™ or CFA specification compatible media. "CompactFlash™" is a registered trademark of SanDisk Corporation, U.S.A. Other company names and product names/brand names are trademarks or registered trademarks of the respective companies.

Equipment operation management system

JaNets JT Simple

Ongoing work on the factory floor is visible, IoT leads to a bright future

JaNets

Juki advanced Network system



The productivity of your factory can always get better!

The first step to increasing productivity is to know the status of your sewing factory now.



*1 Idle waiting time and irregular tasks (e.g., thread changing) that divert the operator from sewing, preparing, and handling materials.
 *2 Operators working at different speeds. When your factory line is in good balance, your operators work at a uniform speed. When the balance is poor, a delay by one operator slows the next processes down the line.

JaNets is JUKI-provided IoT service to help customers increase productivity.



Catalog PDF

With **JaNets** you can instantly find the parts of your factory you need to improve!



Operation rates are clear to **See!**

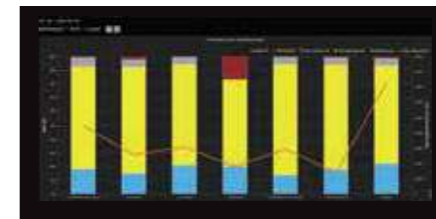

With JaNets, you can track operation metrics that you could only grasp with your senses before.

See sewing machine troubles instantly!



With JaNets, you can check which equipment has failed or caused irregular tasks, how often the failures and tasks have taken place, and for how long.

See processing times instantly!

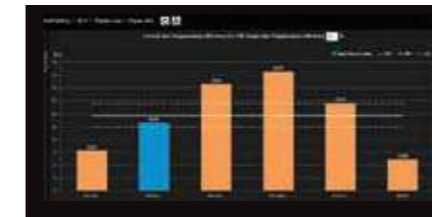

With JaNets, you can check how much time an operator spends working on a garment.

See the progress of your line in real time!



With JaNets, you can check your production progress without spending man-hours.

See your output quantities!

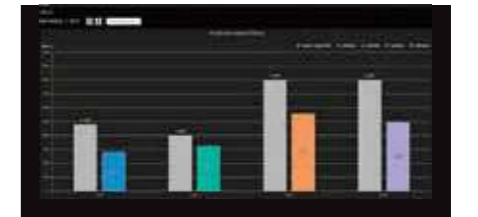

With JaNets, you can check the target/actual output quantity of each piece of equipment.



Other advantages JaNets provides

Reduced waste

Factory operators with enhanced awareness

Enhanced responsiveness to labor shortages

Increase the productivity of your factory further!

Why not get started with JUKI?

Contact JUKI to learn more about JaNets!



Website



Catalog PDF

守 破 離

JUKI-ShuHaRi Free registration

JUKI-ShuHaRi is applications that works with IoT (Internet of Things) devices such as smartphones and PCs to support sewing machine maintenance and solve problems on the sewing line!

Product website https://www.juki.co.jp/industrial_e/service_e/shuhari/



For more information and to apply for the JUKI-ShuHaRi, scan here!

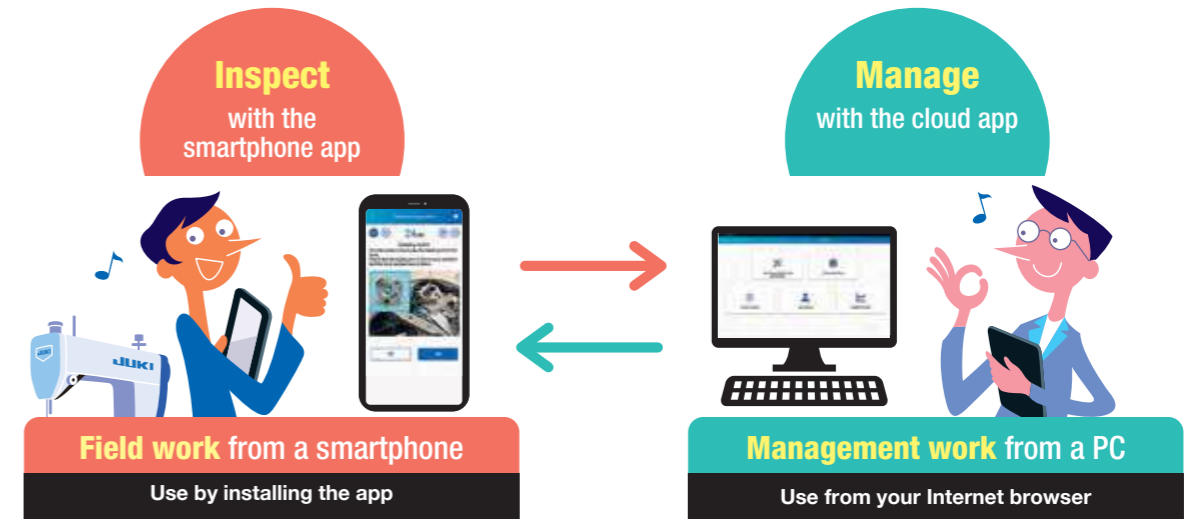

Inspect
with the
smartphone app

Smooth inspection with JUKI-ShuHaRi using a smartphone or tablet

Complete complex inspections with the Smartphone app

Select "Daily Inspection" or "Periodic Inspection" from the "Inspection Management" menu in your smartphone app and capture an image of the sewing machine nameplate with your smartphone camera. JUKI-ShuHaRi will recognize your machine model from the image and launch the inspection. (A QR code search function is also available.)

The smartphone app guides you through the inspection with a simple sequence of images.

When the inspection launches, carry out the steps in sequence according to the instructions in the smartphone app.

The captured image of the nameplate automatically identifies your machine.

Three types of Maintenance functions

Daily inspection <small>can be completed in five minutes</small>	Periodic inspection <small>carried out in detail</small>	Work report <small>wherever and whenever you want</small>
<ul style="list-style-type: none"> ● Simple inspections anyone can perform to keep the machine in proper running condition. ● Recommended for short periods of downtime such as before or after working hours. ● Inspection mode for easier inspections. 	<ul style="list-style-type: none"> ● An inspection of deteriorated parts and defects performed in advance to prevent troubles and maintain machine performance. ● Inspections optimized based on the period of use ensure easy sewing machine management. ● An inspection mode for carrying out inspections in detail. 	<ul style="list-style-type: none"> ● Freely add photos and comments to your reporting data. ● Operations such as machine adjustments, parts replacements, and line changeovers can be recorded in daily work histories to facilitate sharing and confirmation.

Manage
with the
cloud app

Efficient management using JUKI-ShuHaRi on a PC.

Maintenance record

Sewing-machine inspection results and work reports are managed collectively in a maintenance record that gives users a clear, big-picture view of the sewing machine conditions.

Inspection results

Replacement parts

Work report

Information distribution function

Information can be distributed and shared using the smartphone push notification.

This function can also be used as a new internal-communication channel!

Notification when an inspection is recommended for a particular machine

Sharing of internal-communications, work standards, and work requests

Sharing of helpful information from JUKI

Analysis function

Inspection data and sewing machine data stored in JUKI-ShuHaRi are analyzed through the cloud app. Multiple data sets in combination enable various types of analysis.

Data recorded in JUKI-ShuHaRi

Number of inspections performed	Inspection time
Number of replacement parts installed	Working hours
Number of faulty parts in inspections	Number of parts estimations

Analysis of sewing machine defects

Analysis of the skills of the persons in charge

45

46

A human resource development program designed for the sewing industry



Catalog PDF

JUKI e-learning

“New employee training” and “staff training”
—**JUKI e-learning** is the perfect solution for both!

Learning individually! Individual training type



The individual training type is provided in a standard e-learning format. The training participant takes the individual e-learning courses using Individual PC, tablets or smartphone. The management user can manage his/her progress on the web.

The Individual e-learning training is recommended for the following customers

Customers who can prepare an internet connection and device for every training participant.

Customers who cannot provide group training because of heavy workloads and restrictions on gatherings during the coronavirus pandemic.

Customers with many employees spread across multiple remote locations.

Fee structure [monthly fee system]

Management fee

Course learning period

- This is the fee for using the system with management user privileges. (At least one management user account is required for each application.)
- With management user privileges, the progress of the participants (learning status, test scores, etc.) can be managed.

Course fee

Number of participants

- This is the fee for a training participant account. (The customer needs to create an account for every participant who takes the course.)
- An individual ID is issued to each participant account. The participant can take the course as many times as he/she wants using his/her ID within the contract period.



Learning the essential basics in the sewing industry

Many people are working in sewing-related industries around the world. Yet surprisingly few teaching materials have been developed to provide basic knowledge on sewing machines and sewing technology. Sewing machine operators therefore tend to be self-taught. The basic knowledge and skills acquired through **JUKI e-learning** can be immediately applied to daily work.

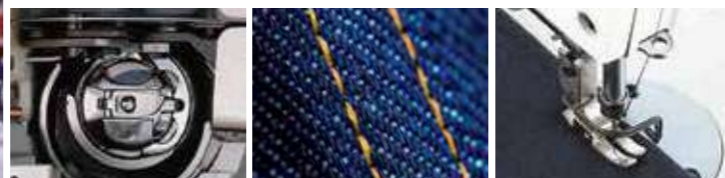

Gaining knowledge and experience from the online learning system

The **JUKI e-learning** program has been developed based on accumulated know-how and experience JUKI has acquired in technical training and management training over its long history. With easy-to-understand videos and narrations, training participants can seamlessly learn wide-ranging topics and skills. At the end of each chapter, the participant takes a test to confirm how well he/she understands the content.

Two different types of training are provided:
Customers can select the type that suits your condition.

Individual training type

Group training type

Learning together! Group training type



The group training type is provided in a lecture format using **JUKI e-learning** materials. The group training is conducted with a large number of participants at the same time. To carry out group training, an instructor has to be prepared within the customer's company.

The group e-learning training is recommended for the following customers

Customers who cannot provide separate internet connections and devices for all of their training participants.

Customers who want to provide all of the training in a single session to lower their costs.

When a customer wants to provide training in an unsupported language, the customer's instructor will translate the e-learning materials to be used for the training.

Fee structure [monthly fee system]

Package fee

- Contract period: At least one month
- Number of participants: Unlimited



Course Introduction

Sewing Operator Training course

- English
- Japanese
- Bengali
- Indonesian
- Vietnamese
- Hindi

Five chapters in total

- Chapter 1** Apparel industry and apparel production
- Chapter 2** Basic knowledge of needles, threads and sewing machines
- Chapter 3** Operation and adjustment of lockstitch sewing machines
- Chapter 4** Practice for lockstitch sewing machines
- Chapter 5** Operation and adjustment of overlock sewing machines

★Content for "practical exercises" can be found in Chapter 4. The training participant carries out hands-on practice using sewing practice sheets provided separately.

Basic Knowledge of Sewing Lockstitching course

- English
- Japanese
- Vietnamese
- Hindi

Eight chapters in total

- Introduction** six major elements of machine sewing
- Chapter 1** Needle bar
- Chapter 2** Hook
- Chapter 3** Thread take-up
- Chapter 4** Feed mechanism
- Chapter 5** Presser foot
- Chapter 6** Thread tension control system
- Chapter 7** Summary

Managerial Training Course Production Design

- English
- Japanese

Six chapters in total

- Chapter 1** What is production design?
- Chapter 2** Organization efficiency
- Chapter 3** Process Distribution
- Chapter 4** Layout
- Chapter 5** Examination of production systems
- Chapter 6** Summary

Coming soon Additional courses will be provided, one by one!
Basic Knowledge of Sewing Chainstitching course

For more information and to apply for the JUKI e-learning, scan here!
Please check the JUKI website for the latest supported languages.
https://www.juki.co.jp/industrial_e/service_e/elearning/



Product website

Plastic Bobbin

Fusion of function and strength. Reinforced plastic bobbin made in Japan with excellent durability and strength.



Catalog PDF

JUKI's new reinforced plastic bobbin will help you to solve the problem.

- It takes time to adjust the thread tension.
- Irregular stitches on light-weight materials.
- Stitching is unstable at high and low speeds.
- Loose stitches at the start of sewing.

Reduction of weight

Since the plastic bobbin is lighter than aluminum and iron, the thread tension is stable at a high level. Furthermore, it realizes beautiful stitching.

High durability

Since there is almost no rubbing inside the bobbin case, it is as durable as aluminum and iron.

Reduction of running idle

Thread bending that occurs after intermittent stitching or thread trimming is reduced. Needle thread tension at the start of sewing is reduced, and stitching is more stable. It also reduces the effect of the remaining bobbin thread amount on the thread tension.

Applicable model	Set part No. (10pcs.) Blue	Set part No. (10pcs.) Red	Set part No. (10pcs.) Yellow
For lockstitching	40244783	40245124	40245136
For 2-fold hook lockstitching	40244784	40245125	40245137
For 2-needle	40244785	40245126	40245138
For Zigzag/Button hole	40244786	40245127	40245139
For bar tacking	40244787	40245128	40245140
For computer-controlled cycle machine	40244788	40245129	40245141



Pack of 10 bobbins

Ti-Mo-N Coating Looper

Better Frictional Resistance, Better Thread Slip, New Loopers from JUKI

Ti-Mo-N film surface treatment on the loopers provides low friction and wear resistance. Smooth thread feeding improves the quality of sewing.

Long Life

Ti-MO-N film is a kind of titanium alloy coating film, which achieves long life like TiN or TiAlN. The surface is covered with a film with high hardness to prevent wear.

Wear Test of Thread Path

Under the conditions of thread winding speed of 2m/s and sliding distance of 200m, spun threads were impregnated with a brasive to promote wear.



Catalog PDF

Low Resistance

No. of TI-MO-N coating part	No. of standard part	Part name	Applicable model
40237550	12968509	LOOPER L	MS-1261 / MS-1261M / MS-1261A
40237551	12968806	LOOPER R	MS-1261 / MS-1261M / MS-1261A
40237552	12969101	LOOPER C	MS-1261 / MS-1261M / MS-1261A
40237553	B2030481000	LOOPER	MH-480 Series
40237556	13424809	LOOPER	MF-7900, MF-7200D Series
40237557	12120705	CHAIN LOOPER	MO-6△16
40237559	13337902	LOOPER	MF-7500 Series
40246367	B242621000B	NEEDLE HOLE GUIDE D=2.0	AMS-E/EN Series
40246368	B242621000D	NEEDLE HOLE GUIDE D=2.4	AMS-E/EN Series
40246369	B242621000F	NEEDLE HOLE GUIDE D=3.0	AMS-E/EN Series
40246467	11999307	LOWER LOOPER	MO-6700 / MO-6900S Series
40246468	12176004	UPPER LOOPER	MO-6700 / MO-6900S Series
40247112	12176103	UPPER LOOPER	MO-6700 / MO-6900S Series
40249863	B2426280000	NEEDLE HOLE GUIDE	LK-1900BN Series
40257763	12176202	UPPER LOOPER	MO-6△16 (for high lift model)
40257815	11991908	UPPER LOOPER	MO-6△04, 6△14 (for high lift model)
40257816	11999802	LOWER LOOPER	MO for thick thread

Bird-Nest Prevention Device for DDL lockstich machine

The quality of lockstitch at the start of sewing is improved. It can be easily retrofitted and is effective for "bird's nest prevention" at the start of lockstitch.

This is an optional device that can be retrofitted to prevent the "bird's nest" that occurs at the start of sewing in the thread trimming machine. The processing process such as thread trimming at the start of sewing part can be omitted, and productivity is improved. Since the needle thread after thread trimming is clamped, the start of sewing is stable even when sewing is started from the edge of the material.



Catalog PDF



Sample installation of bird's nest prevention device

List of Optional presser foot for Bird's nest prevention device (JSH-PBNB01/JSH-PBNS01/JSH-8000APBNB01/JSH-8000APBNS01)

No.	PART No.	DESCRIPTION	SIZE				
			X	X1	X2	X3	Y
1	JSH-001-11A	Flat presser (Standard Presser Foot)	11	2	-	-	4.4
2	JSH-001R1-4	Presser foot with fixed guide (1/4, right)	16	2	6.4	9	4.45
3	JSH-001R1-8	Presser foot with fixed guide (1/8, right)	13	2	3.2	7	4.45
4	JSH-001R3-16	Presser foot with fixed guide (3/16, right)	16	2	4.8	9	4.45
5	JSH-001L1-4	Presser foot with fixed guide (1/4, left)	16	2	6.4	9	4.45
6	JSH-001L1-8	Presser foot with fixed guide (1/8, left)	13	2	3.2	6	4.45
7	JSH-001L3-16	Presser foot with fixed guide (3/16, left)	16	2	4.8	9	4.45
8	JSH-001R1-16	Presser foot with fixed guide (1/16, right)	13	2	1.6	7	4.45
9	JSH-001L1-16	Presser foot with fixed guide (1/16, left)	13	2	1.6	6	4.45
10	JSH-001R1-32	Presser foot with fixed guide (1/32, right)	13	1.8	0.8	7	4.45
11	JSH-001L1-32	Presser foot with fixed guide (1/32, left)	13	1.8	0.8	6	4.45
12	JSH-001AR1-16	Presser foot with moving guide (1/16, right)	13	2	-	4	4.8
13	JSH-001AR1-32	Presser foot with moving guide (1/32, right)	13	2	-	4	4.8
14	JSH-001AL1-16	Presser foot with moving guide (1/16, left)	13	2	-	4	4.8
15	JSH-001AL1-32	Presser foot with moving guide (1/32, left)	13	2	-	4	4.8
16	JSH-001AR1-4	Presser foot with moving guide (1/4, right)	16	2	6.4	9	4.8
17	JSH-001AR1-8	Presser foot with moving guide (1/8, right)	15	2	3.2	8	4.8
18	JSH-001AR3-16	Presser foot with moving guide (3/16, right)	16	2	4.8	8	4.8
19	JSH-001AL1-4	Presser foot with moving guide (1/4, left)	16	2	6.4	9	4.8
20	JSH-001AL1-8	Presser foot with moving guide (1/8, left)	15	2	3.2	8	4.8
21	JSH-001AL3-16	Presser foot with moving guide (3/16, left)	16	2	4.8	8	4.8

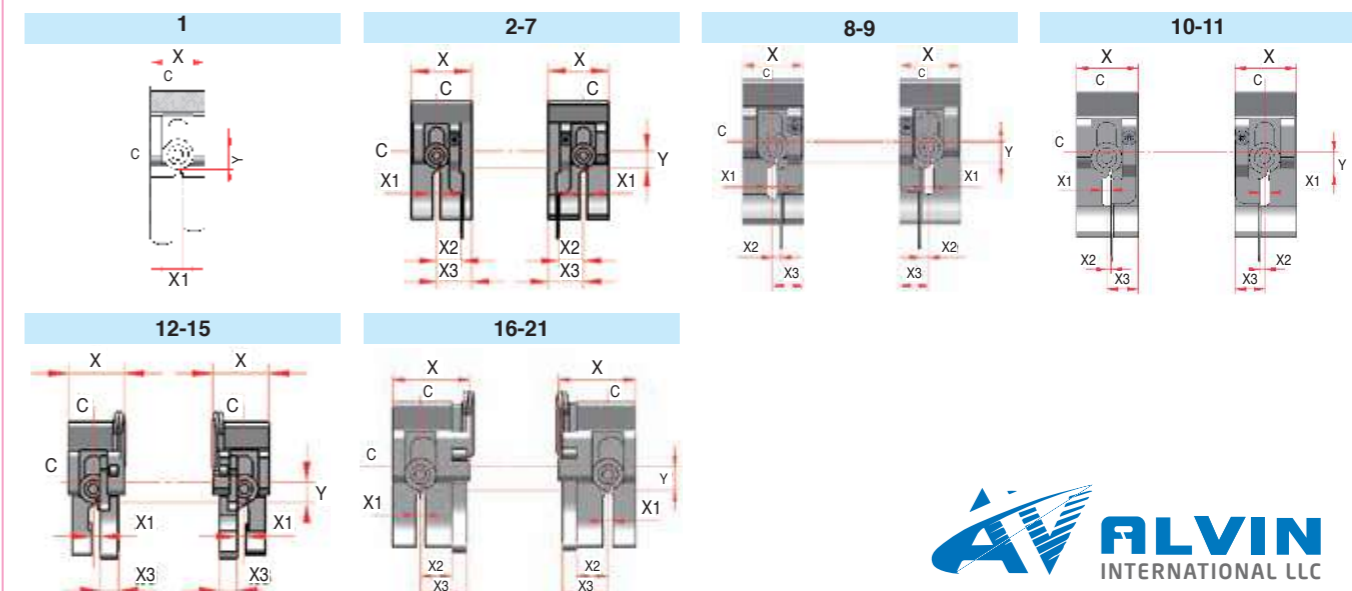

DDL-9000C Series Optional Items

Proposing Optional DDL-9000C Items that Further Improve Productivity and Sewing Quality



Catalog PDF

Applicable Models

- Premium Digital** **DDL-9000C-FMS**
(Medium-weight / Semi-dry)
- DDL-9000C-FSH**
(Heavy-weight / Minute-quantity lubrication)
- Digital** **DDL-9000C-SMS**
(Medium-weight / Semi-dry)
- DDL-9000C-SSH**
(Heavy-weight / Minute-quantity lubrication)



DDL-9000C

List of DDL-9000C series optional products

○ Can be fitted — Not applicable

No.	Parts no.	Description	Full-digital	Digital
①	40188622	THICKNESS SENSOR ASM.	Standard	○
②	40194389	MICRO LIFTING DEVICE ASM. FOR S	Digital	○
③	JSH-PBNB01	BIRD NEST PREVENTION DEVICE (Backhold type)	○	○
	JSH-PBNS01	BIRD NEST PREVENTION DEVICE (Side-mounted type)	—	○
④	40065571	ELECTRIC FAN HOOK COOLING DEVICE	○	○
⑤	40065552	THROAT PLATE SCREW (Fixed pin type)	○	○
⑥	22970404	NEEDLE BAR THREAD HOOK	○	○
⑦	40206843	KNEE TYPE LIFTING DEVICE (Electronic control)	○	Manual
⑧	40174617	AUTO-LIFTER AK-154 (foot-pedal type)	Standard	○
⑨	40257811	3-POSITION PRESSER FOOT HOLDER (For DDL-9000C-F)	○	—
	MAS07300AA0	3-POSITION PRESSER FOOT HOLDER (For DDL-9000C-S)	—	○
	40172389	Presser bar cap (for Full-digital)	○	—
⑩	40197869	SUPER SHORT THREAD GAUGE SET (4-row)	○ (S-type only)	○ (S-type only)
⑪	40209906	PARTS KIT_9000C_S (ACC) (S-type: Midium)	○	○
	40209907	PARTS KIT_9000C_H (ACC) (H-type: Heavy)	○	○

Besides the catalogs, we ask you to purchase the following products.

⑫	22890206	RP HOOK (Dry-hook)	○	○
⑬	22890404	RP HOOK-C (Dry-hook/with needle guard)	○	○
⑭	27003557	HOOK ASM. (for No-rotation bobbin)	○	○
⑮	27003755	BOBBIN CASE ASM. (for No-rotation bobbin)	○	○
⑯	27003805	NO-ROTATION BOBBIN	○	○

LK-1900 Shorter Thread remaining Kit

The thread trimming work in the bartacking process can be eliminated. It can be easily retrofitted and the productivity of the bartacking process increases.

The shorter-thread remaining function can be added to your sewing machine only by replacing with the dedicated throat plate kit. The length of the needle thread remaining on the back side of the material at the end of sewing is 2.5 mm or less on average.

It eliminates the need for thread trimming operation and gives soft and smooth feeling on the bartacking sections where directly contact skin such as underwear and other items.



Catalog PDF

Modified parts on a model basis

Applicable models	Sewing category	Part Number
LK-1900A / 1900AN / 1900B / 1900BN	Standard (S)	40193911
	Heavy-weight materials (H)	40194944
LK-1903A / 1903AN / 1903B / 1903BN	Button sewing	40193911
		40193915

List of consumables

Part Name	Part Number
Moving knife ①	40193905
Fixing knife ②	40193912
Needle Hole Guide ③	40193909 (S Spec)
	40193914 (H Spec)
	40193915 (Button sewing)

- In the case of a button sewing machine, it is necessary to replace the shorter-thread remaining throat plate kit and the dedicated needle hole guide.
- All applicable models require special software

LK-1900 Instant Button Sewing Clamp Kit

This is a conversion kit from a bartacking machine to a button sewing machine.



Catalog PDF

Various button sizes can be supported. (Outer dia. 8 to 21 mm, thickness 1 to 4.5 mm can be sewn up to a hole spacing of 4.5 mm) Since the presser foot pressure is concentrated on the tip of the button clamp jaw lever, sewing defects due to displacement of the material are eliminated. Since the presser foot operates vertically, there is no deviation of the button center position due to the thickness of the material.

Bartacking process

Button Sewing Clamp Kit

Button sewing process

Applicable models

LK-1900BN LK-1900B
LK-1900AN LK-1900A

1 VERTICAL_BUTTON_ATTACHED_DEVICE

2 FEED_PLATE_A

Simply replace!

Standard accessory

3 4 Extra small thin button

5 6 Middle & Large thin button

7 8 9 Button floating dev.

10 Boss guide

11 For LK-1900A

Button Sewing Clamp Kit Parts List

No.	Part Number	Part Name
①	40205494	VERTICAL_BUTTON_ATTACHED_DEVICE
②	72002988	FEED_PLATE_A
③	72005816	SPRING_LEFT_B
④	72005817	SPRING_RIGHT_B
⑤	72005821	SPRING_LEFT_C_ASM
⑥	72005822	SPRING_RIGHT_C_ASM
⑦	72003011	BUTTON_RISING_BAR
⑧	SS6080340SP	SCREW 1/8-44 L=2.9
⑨	WP0370316SD	WASHER 3.7x8x0.3
⑩	MAZ15601000	GUIDE
⑪	72002987	LENGTHWISE_FEED_SENSOR_SLIT
⑫	40021011	SMALL_GAUGE